

# Inverter Salt Chlorinator

## Operating Instructions



**Mr. Pure Pro**



# INDEX

1 Warnings.....	1
2 Product Introduction .....	2
2.1 Product Specification .....	2
3 Installations and Connections .....	3
3.1 Materials and Tools .....	3
3.2 Installations Diagram .....	3
3.3 Control Unit .....	5
3.4 Electrolytic Cell.....	6
3.5 Probe Cell .....	7
3.6 External pH Doser (Optional).....	9
3.7 In-built pH Doser .....	12
3.8 Electronic Connections .....	14
4 Pool Water Preparation .....	20
4.1 Adding Salt.....	20
4.2 Chemical Water Balance .....	20
5 Control Unit Operation.....	21
5.1 General Screen View .....	21
5.2 Chlorine Production Mode Introduction .....	24
5.3 LED Indicator Introduction .....	26
5.4 Basic Commands and Functions .....	27
5.5 Combinations and Operation .....	37
6 Salt Replenishment .....	40
7 Maintenance .....	41
7.1 Cleaning the Electrodes.....	41
7.2 Maintenance of the ORP Probe (Only Premium) .....	41
7.3 Maintenance of the pH Probe (Premium/Medium) .....	41
7.4 Maintenance of the Doser (Optional).....	42
8 Winterizing and Low Temp Protection.....	43
9 Overheat Protection .....	43
10 Wi-Fi Instruction and iGarden App .....	44
10.1 Start-Up.....	44
10.2 Networking Configuration.....	44
10.3 Remove Control .....	49
10.4 OTA Upgrade .....	51
10.5 Device Sharing.....	51
10.6 Change Language Settings .....	52
11 After-Sales Support .....	56

# 1 Warnings

## **WARNING: General Information**

1. Carefully read all the instructions in this manual and on the device. Failure to read and comply with the instructions can cause injury. This document must be given to the pool owner / custodian, who should keep it in a safe place for reference.
2. Chemicals can cause internal and external burns. To avoid death, serious injury and/or damage to equipment, always wear personal protective equipment (gloves, goggles, mask, etc.) when servicing or maintaining this device. This device must be installed in an adequately ventilated place.
3. The appliance is not to be used by persons (including children) with reduced physical, sensory, or mental capabilities, or lack of experience and knowledge, unless they have been given supervision or instruction.
4. Children must not play with this device. User maintenance and cleaning must not be carried out by unsupervised children.
5. The chlorinator must be located or fixed so that they cannot fall into the water.
6. Avoid damage due to water freezing.
7. Use only original Aquark parts.

## **WARNING: Electrical Hazard**

1. This appliance is intended to be used on swimming pools only.
2. The control unit is recommended to be installed in the pool machine room.
3. Disconnect the equipment from the mains supply before any intervention or maintenance.
4. All electrical installations must be carried out by a qualified and approved electrician in accordance with the standards currently in force in the country of installation.
5. Check that the device is plugged into a power outlet that is protected against short-circuits. The device must also be powered via an isolating transformer or a residual current device (RCD) with a nominal operating residual current not exceeding 30 mA.
6. Check that the supply voltage required by the product corresponds to the voltage of the distribution network and that the power supply cables are suitable for the products power demand.
7. To reduce the risk of electric shock, do not use an extension cable to connect the device to the mains. Connect directly to a wall socket.
8. This device must not be used if the power cord is damaged. An electric shock could result. A damaged power cord must be replaced by after-sales service or similarly qualified persons to avoid danger.

# 2 Product Introduction

## 2.1 Product Specification

Model	MPP10	MPP16	MPP24	MPP32	MPP36
Max. Chlorine Production (g/h) (Salinity: 1000 PPM)	10	16	24	32	36
Pool Volume (m <sup>3</sup> )	40~50	50~75	75~100	90~125	120~140
Recommended Salinity(g/L)	1-2g/L (recommended 1g/L)				
Power Supply	AC 220 – 240V 50/60Hz				
Max. Output Voltage	DC 12V				
Max Input Power(W)	88W	135W	202W	225W	252W
Advised water flux(m <sup>3</sup> /h)	5 – 28				
Operating Water Temperature(°C)	5 – 40				
Ambient Temperature(°C)	-7 – 42				
Pressure for Electrolytic Cell (Bar)	3				
Cell Lifetime(H)	Up to 12000				
Electrolytic Cell Type	OneCell			Modular Cell	

# 3 Installations and Connections

## 3.1 Materials and Tools

Tools Needed for Installation
Tape Measure
Phillips and Flathead Screwdrivers
Pliers Drill
Drill
Hacksaw
Waterproof for Pool Pipes
PVC primer and glue

## 3.2 Installations Diagram

### 3.2.1 Control Unit with In-Built pH Doser

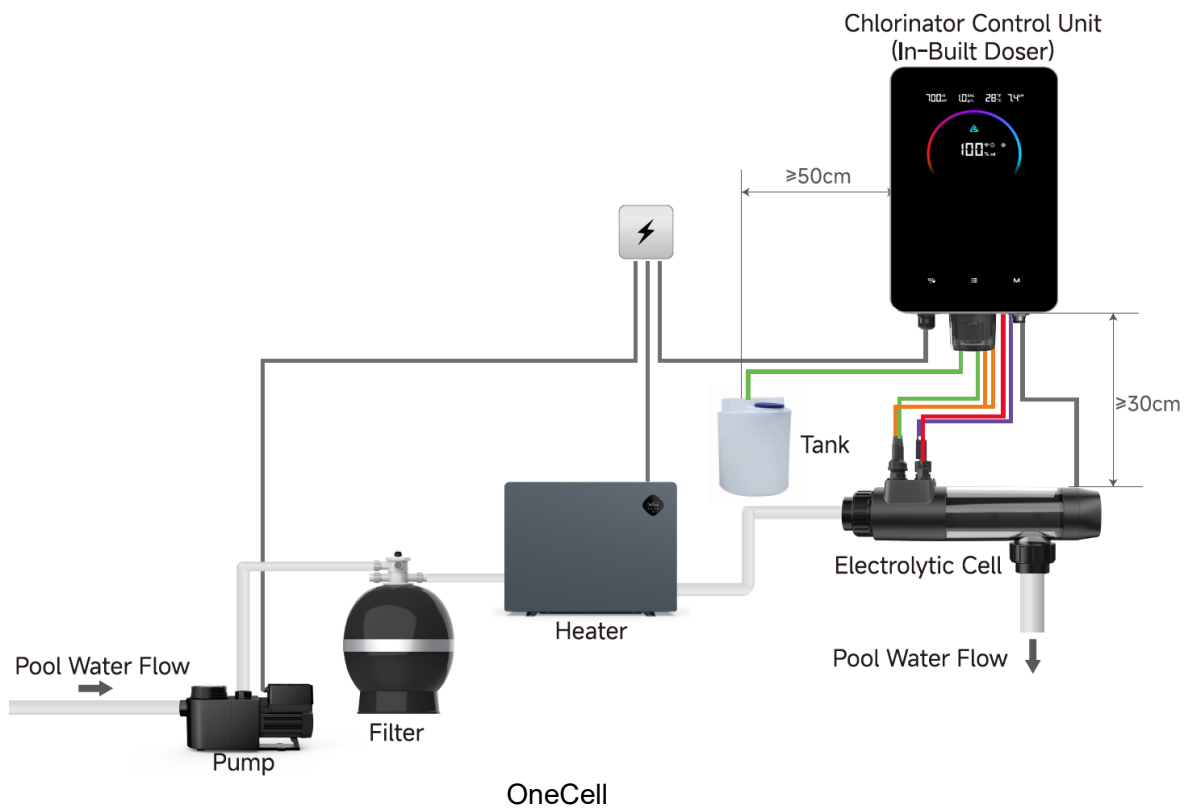

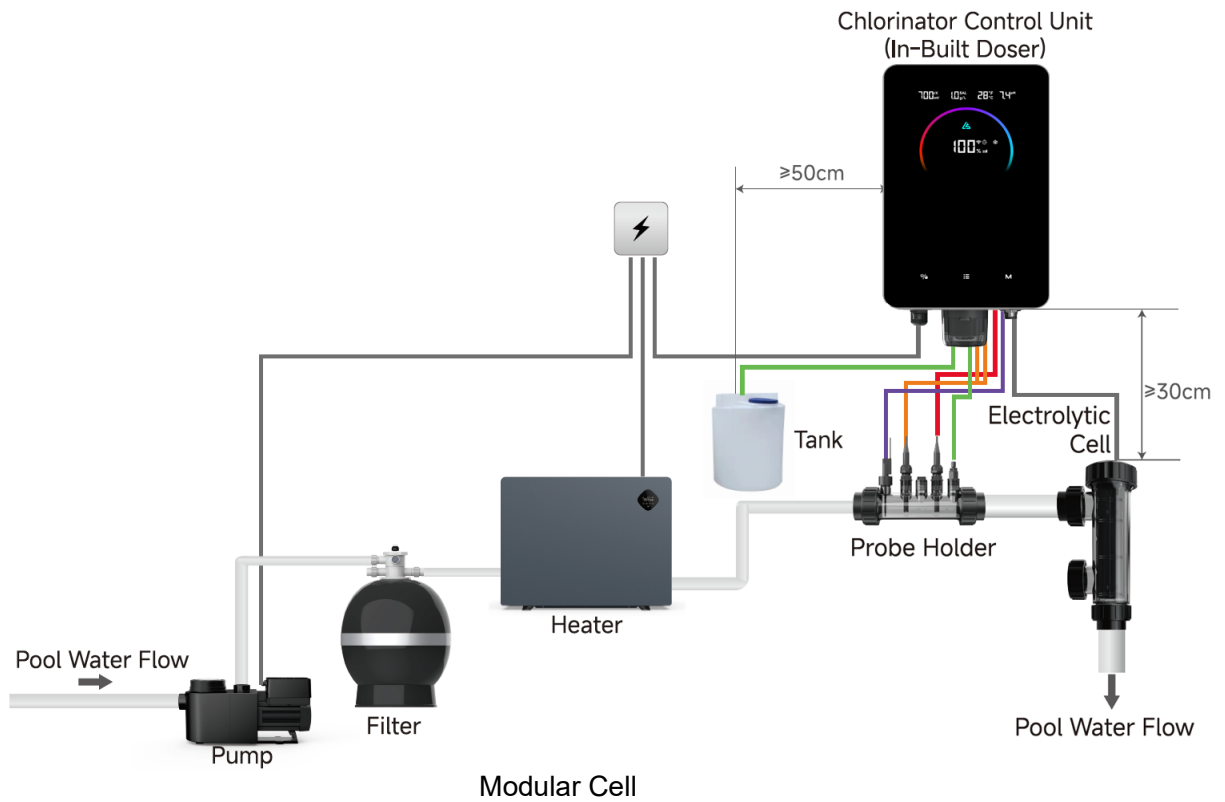

### 3.2.2 Control Unit with External pH Doser

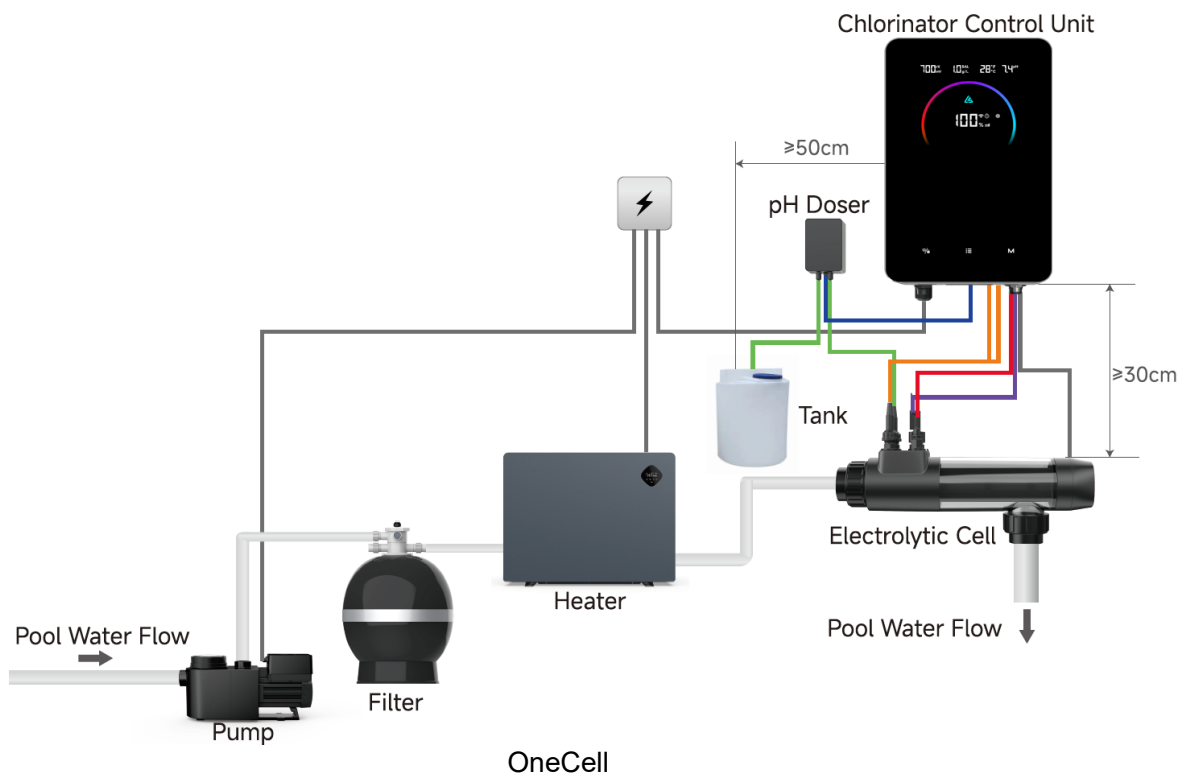

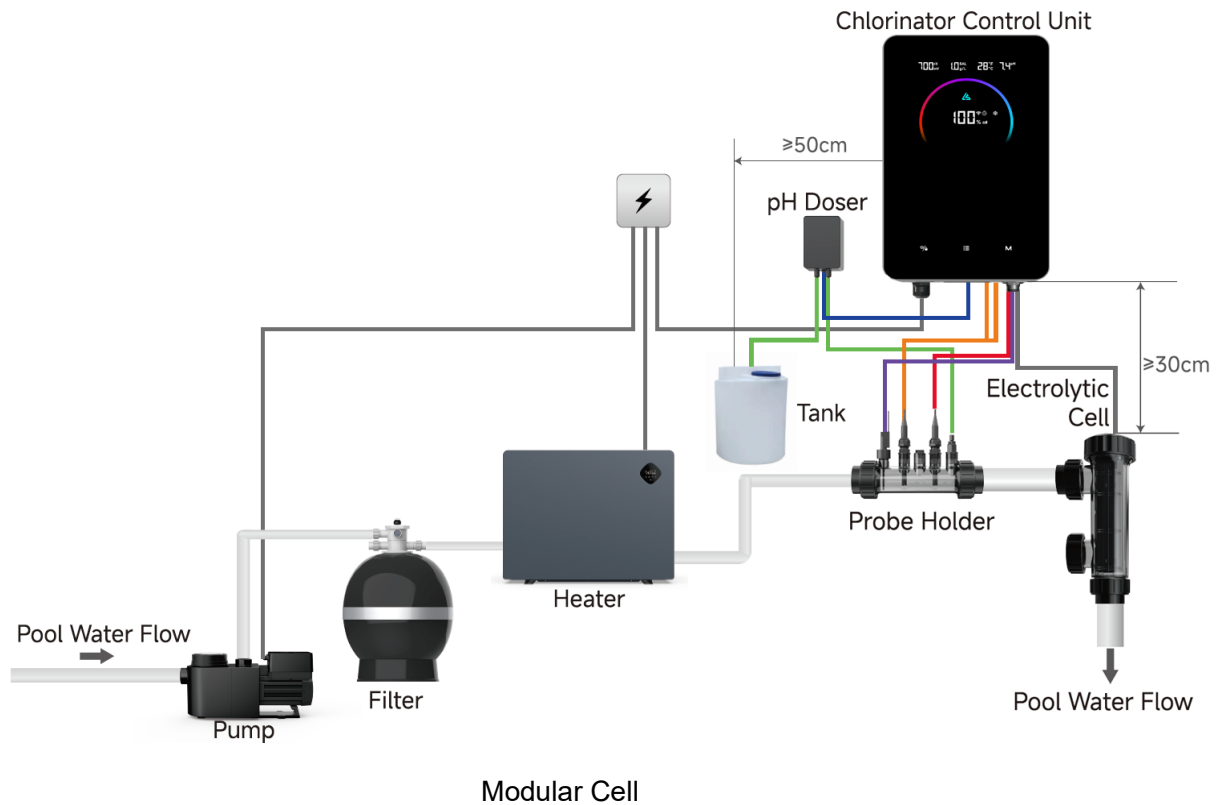

### 3.3 Control Unit

**Note:**

- **The control unit is recommended to be installed in the pool machine room.**
- For safety and user convenience, the control unit should be installed from the ground at least 80cm.
- **Don't place the control unit directly above an open chemical container or tank.**
- It is suggested to place the salt chlorinator control unit keeping a distance from the chemical container or tank, **more than 2m is better.** (The minimum distance between the control unit and the sealed acid barrel must be 50cm)
- The unit should also be kept away from heat sources. Proper ventilation is essential for correct operation.
- Electrolysis cell is connected to control unit with a **1.8m cell cable.**
- Control unit should be installed at least 30cm higher than electrolysis cell.
- Connect the control unit power supply to an appropriate weatherproof power outlet/controller.
- For easy maintenance, the control unit can be taken out from the mounting surface freely, without any excess operations.

1. Using the wall-mounted backplate as a guide, mark holes on the mounting surface where the control unit will ultimately reside. Drill the holes in the mounting surface.
2. Insert the expansion plugs into the borehole.
3. Reinstall the wall-mounted backplate to the top and bottom of the back of the control unit using the screws that were removed.
4. Tighten all the screws, ensuring that the control unit is securely hung on the mounting surface.
5. Check source voltage.

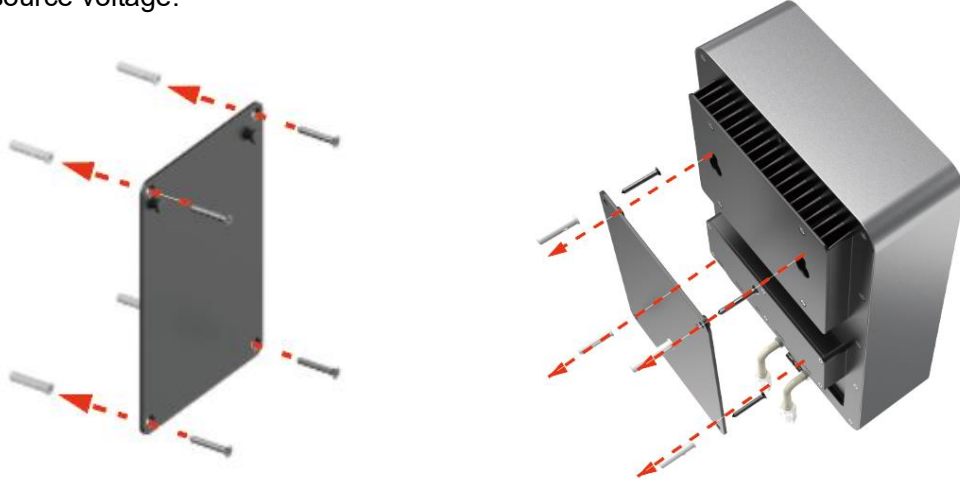

### 3.4 Electrolytic Cell

**Note:**

- Before installation, make sure pool pump is turned off.
- It is recommended that the electrolytic cell be installed in the pool return line after the filter and heater.
- The solvent cement or primer can cause damage if allowed to contact the threads or the o rings.
- Failing to install in the correct way may cause products faults and void warranty.



OneCell

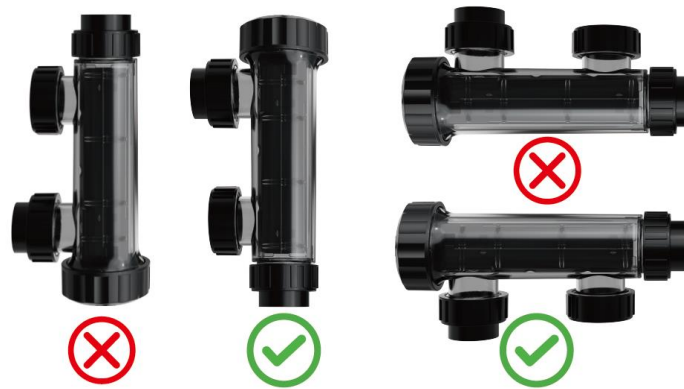

Modular Cell

1. Shown below are 2 different cell orientations:
2. The power supply connection cap must be the highest point of the installation.
3. Ensure adequate water flow over the cell plates.
4. Make sure the higher water level in the electrolytic cell, and the power supply connection cap is the highest point.
5. The cell is supplied with 48.3mm, 50mm, 60.3mm and 63mm unions to connect to the PVC plumbing.
6. Ensure a suitable solvent cement is used to glue the unions to the pipework.
7. Ensure the nuts are over the union tails before gluing them onto the pipework.
8. Once the solvent cement has set, place the cell housing onto the pipework and hand tighten the union nuts with the o rings in place.

### 3.5 Probe Cell

**Note:**

- Before installation, make sure pool pump is turned off.
- Failing to install in the correct way may cause products faults and void warranty.
- Probe Cell only be installed horizontally.

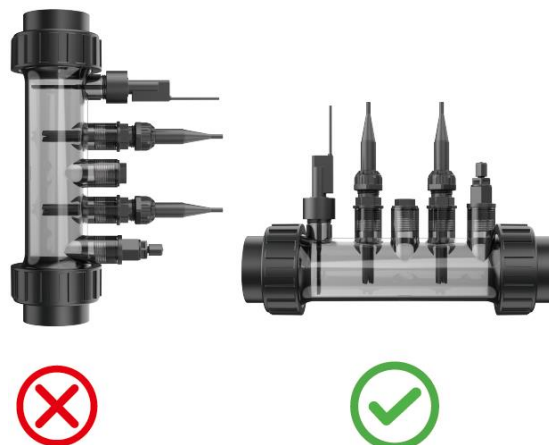

- Flow Switch, pH Probe, ORP Probe, Check Valve (for acid) can be installed according to the recommended sequence.

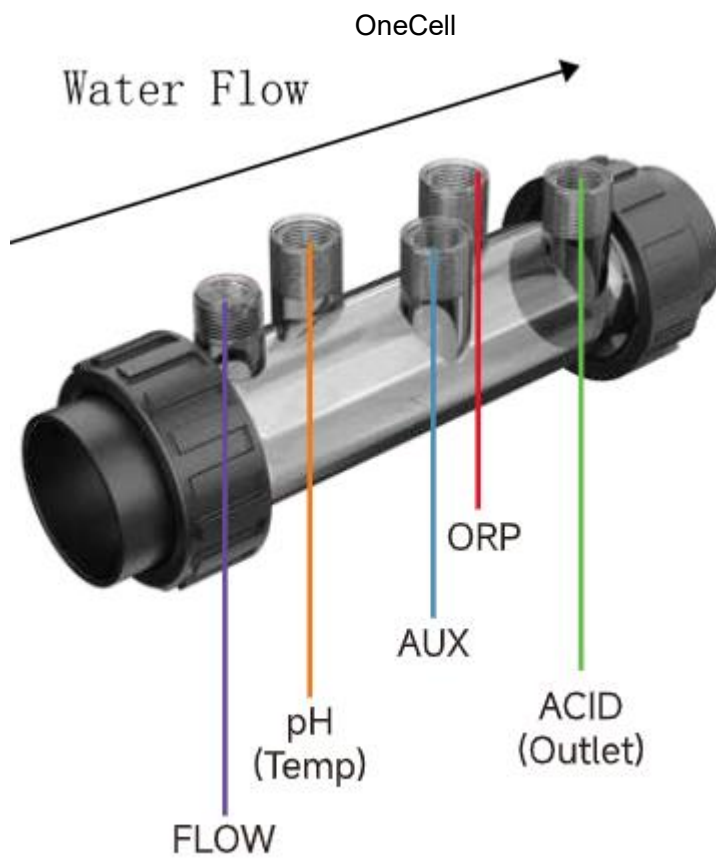
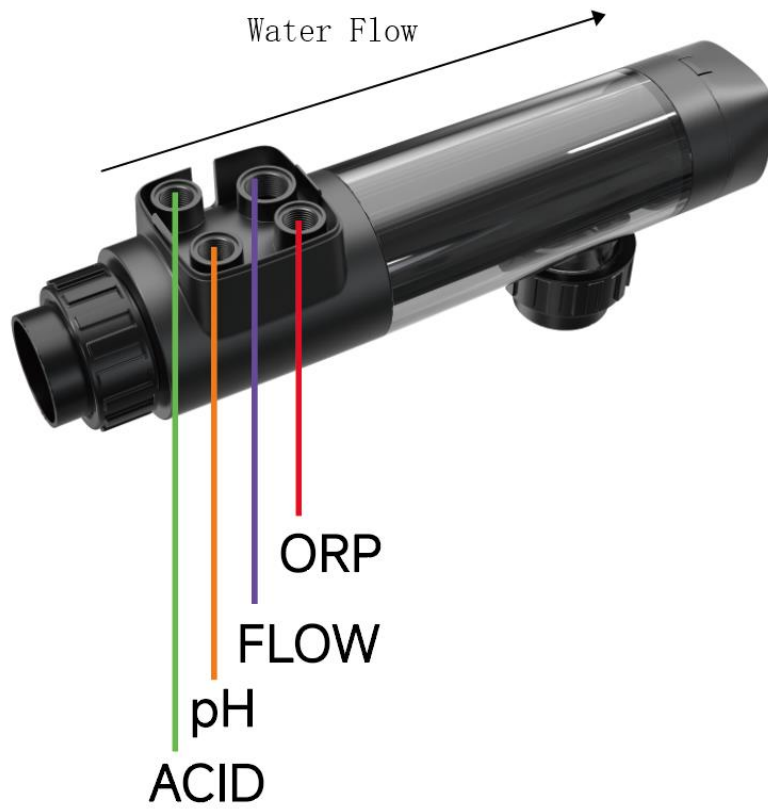

Modular Cell

### 3.6 External pH Doser (Optional)

**Note:**

- It is suggested to use Hydrochloric Acid:  $\leq 12.5\%$  concentration.
- If you're working with chemicals that release strong fumes, **don't place the doser directly above an open chemical container or tank**, as this could cause dangerous reactions and safety hazards.
- The doser should not be installed higher than 1.5m from the ground.

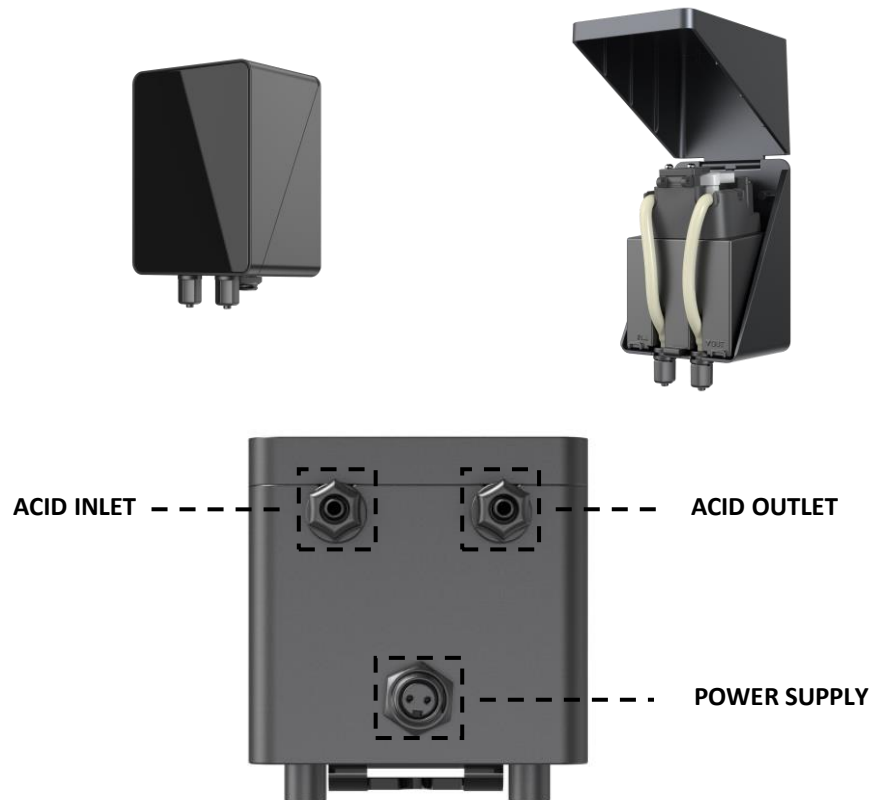

1. Use an impact drill to make holes in the wall and mount the doser in a vertical position. For best results, install this doser on a waterproof mounting panel.
2. Push the tubes all the way onto their connectors until they fit tightly.
3. Secure each connection. by firmly tightening the screws and nuts.
4. Keep the tubes as straight as possible on both input and output sides - avoiding unnecessary bends and curves.
5. Straight tubes paths will help maintain good flow and prevent resistance issues.
6. Apply grease on the peristaltic tube if necessary.

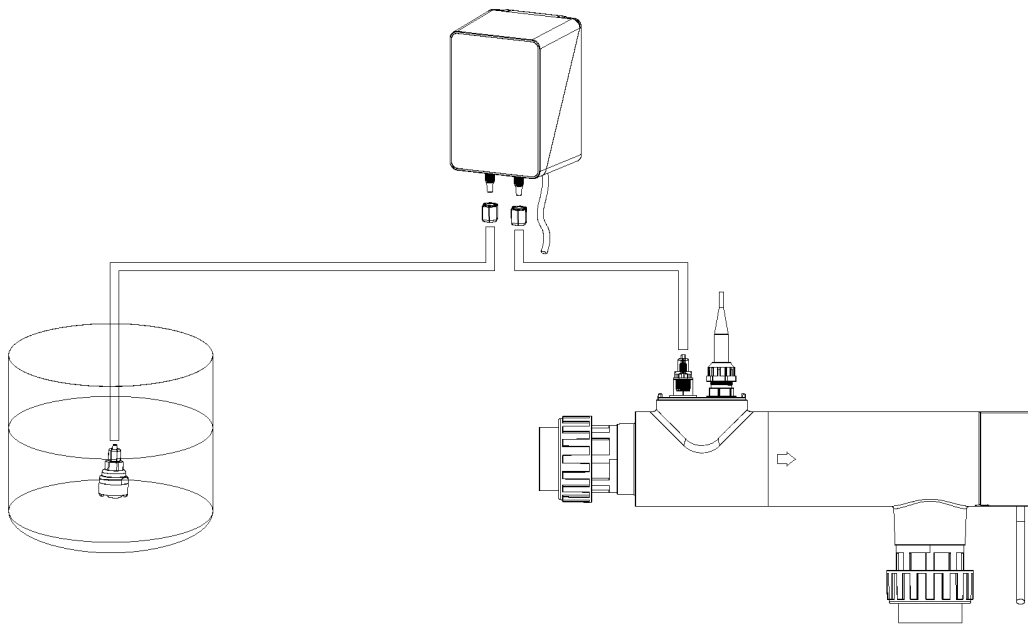

OneCell

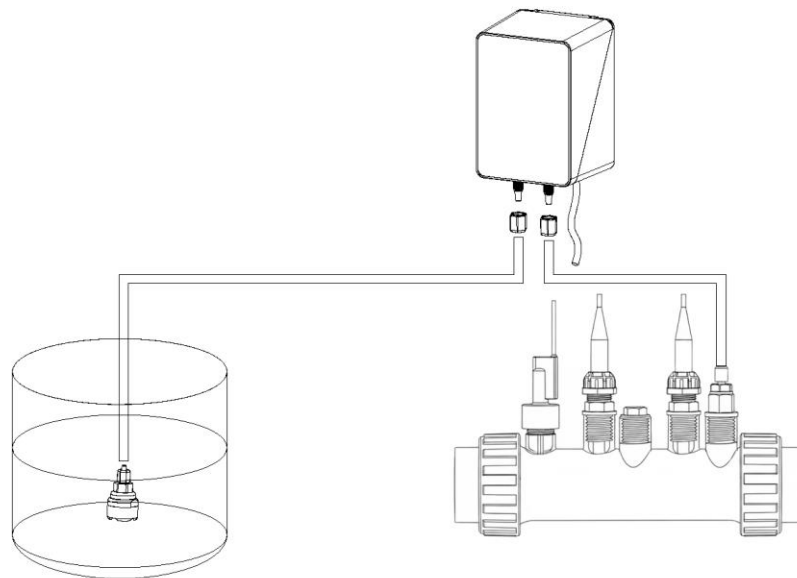

Modular Cell

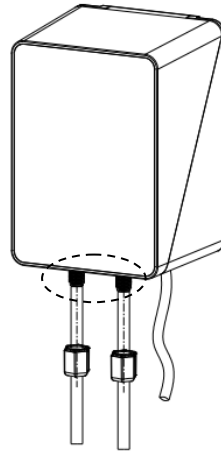
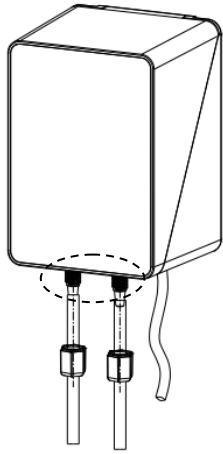

When connecting the acid tube, please be careful about the acid tube leakage

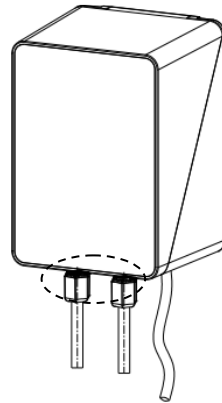
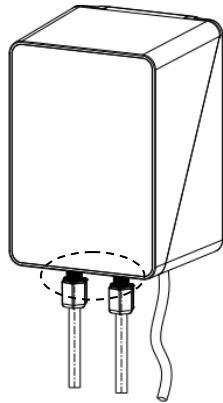

### 3.7 In-built pH Doser

**Note:**

- It is suggested to use Hydrochloric Acid:  $\leq 12.5\%$  concentration.
- If you're working with chemicals that release strong fumes, **don't place the doser directly above an open chemical container or tank**, as this could cause dangerous reactions and safety hazards.



1. Push the tubes all the way onto their connectors until they fit tightly.
2. Keep the tubes as straight as possible on both input and output sides - avoiding unnecessary bends and curves.
3. Straight tubes paths will help maintain good flow and prevent resistance issues.
4. Apply grease on the peristaltic tube if necessary.

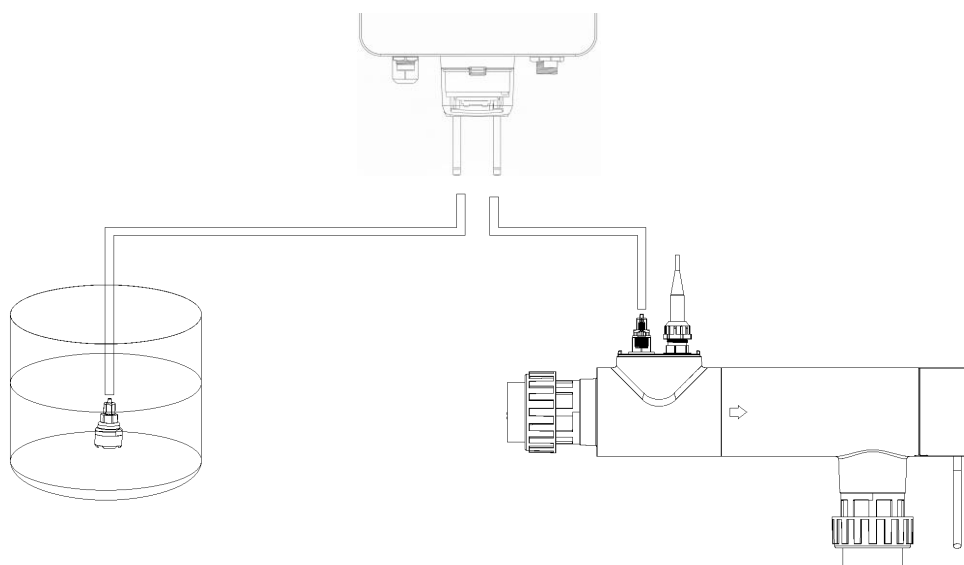

OneCell

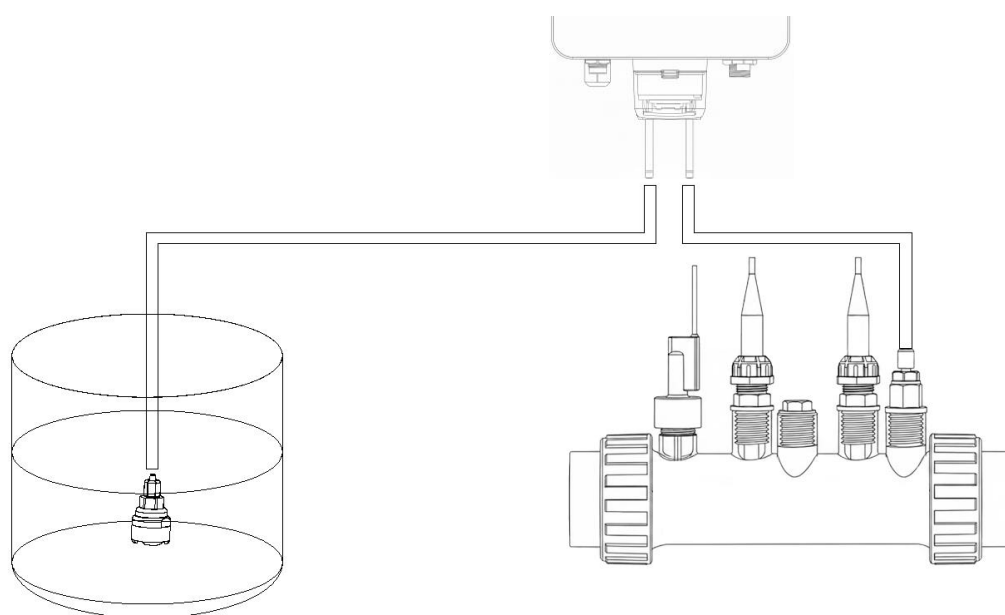

Modular Cell

### 3.8 Electronic Connections



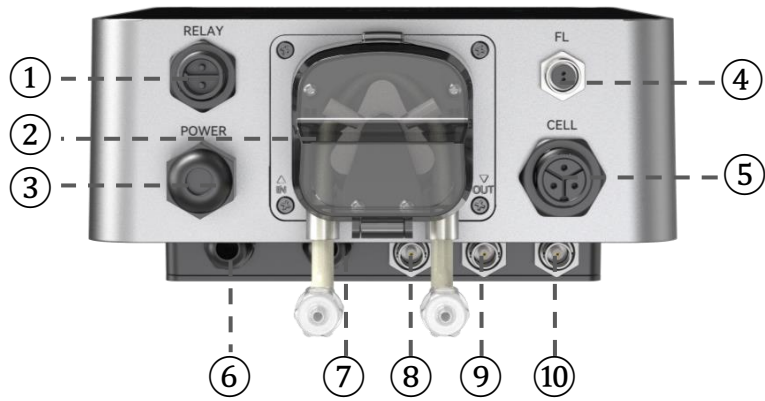





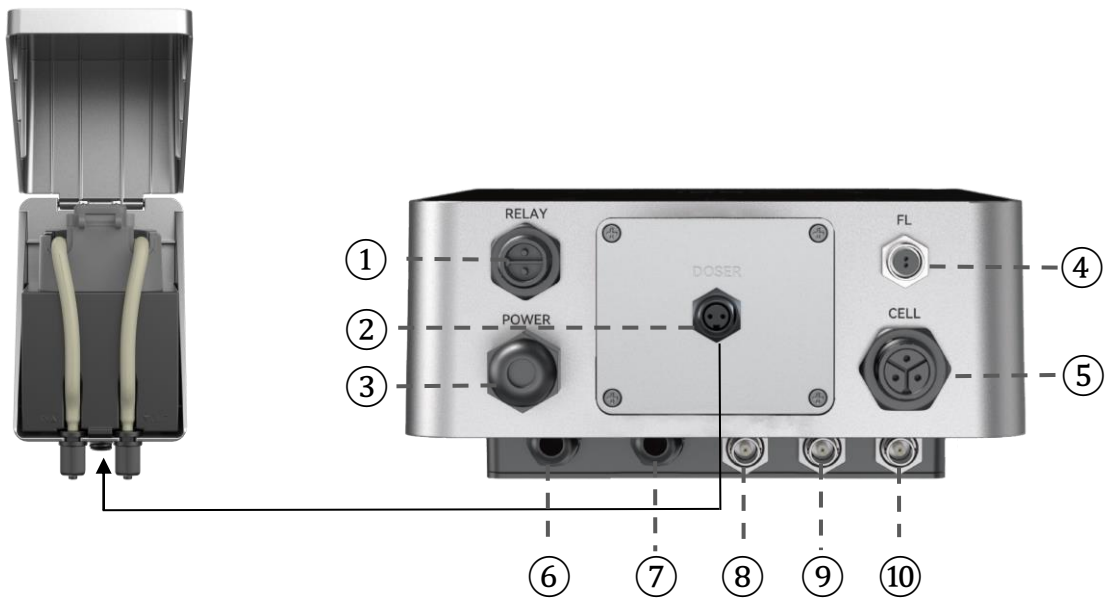

#### 3.8.1 Control Unit with In-Built pH Doser



No.	Port Name	Photo	Description	
①	Relay (Dry Contact)		<b>Connector for dry contact</b> <b>The safe current value &lt; 5A, AC220-240V</b> The internal relay is normally open, used to control the on/off of external water pumps, etc.	
②	In-built pH Doser		Left	Acid inlet
			Right	Acid outlet
③	Power Input		AC power connector (220-240V, 50/60Hz)	
④	Flow Switch		Connector for flow switch	
⑤	Power Output		Terminal for cell power	
⑥	AUX1		External Device Control ( <b>MAX 10mA, 5V DC</b> )	
⑦	AUX2		External Device Control ( <b>MAX 10mA, 5V DC</b> )	
⑧	pH		BNC Connector for pH sensor	
⑨	TEMP		BNC Connector for temperature sensor (Integrated with the pH sensor).	
⑩	ORP		BNC Connector for ORP sensor	

### 3.8.2 Control Unit with External pH Doser



No.	Port Name	Photo	Description
①	Relay (Dry Contact)		<b>Connector for dry contact</b> <b>The safe current value &lt; 5A, AC220-240V</b> The internal relay is normally open, used to control the on/off of external water pumps, etc.
②	External pH doser connection port		Connect the power supply port of the external pH doser
③	Power Input		AC power connector (220-240V, 50/60Hz)
④	Flow Switch		Connector for flow switch
⑤	Power Output		Terminal for cell power
⑥	AUX1		External Device Control (MAX 10mA, 5V DC)
⑦	AUX2		External Device Control (MAX 10mA, 5V DC)
⑧	pH		BNC Connector for pH sensor
⑨	TEMP		BNC Connector for temperature sensor (Integrated with the pH sensor).
⑩	ORP		BNC Connector for ORP sensor

### 3.8.3 Dry Contact Cable Connection (Water Pump)

**Dry Contact Specifications:**

**Type:** Isolated relay contact (NO/NC)

**Rating:** MAX 5A, 110V-240V AC

**Characteristics:**

- No voltage/current supplied by the contact itself.
- Can switch external AC loads up to 5A at 110V-240V.

**Water Pump Control Logic via Dry Contact:**

The operating states and their outcomes are clearly defined in the following logic table:

Chlorinator State / Screen Displayed	Dry Contact Status	Water Pump Action
Chlorinator is OFF	Disconnected	Turned OFF
Setting Screen (after shutdown)	Disconnected	Turned OFF
HOME Screen	Connected	Turned ON
Calibration Screen	Connected	Turned ON

Our product will be equipped with a Dry Contact Cable (1 m), wire the cable as shown in the diagram below:

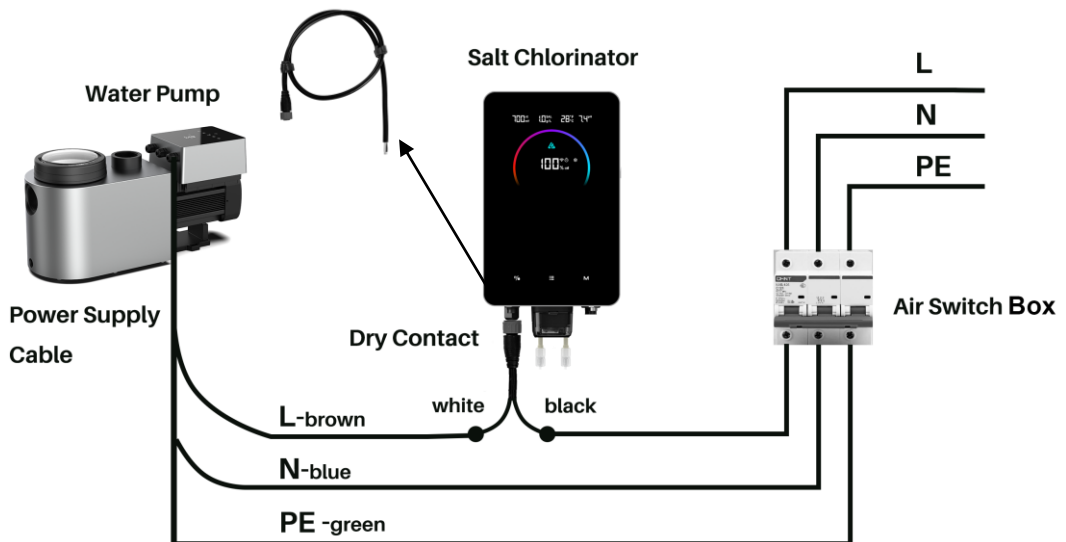

- a) Remove the outer black insulation from the power supply cable of Water Pump that will be connected to the Salt Chlorinator. Three wires inside are exposed (green, blue, brown).
- b) Disconnect three wires of water pump power supply cable.
- c) Install Cable Glands or Connectors: If your junction box uses cable glands, screw them into the entry points of the box. These are used to secure the cable and provide a waterproof seal.
- d) Insert the Wires into the Junction Box: Feed the wires through the cable glands or waterproof connectors into the junction box. Ensure that the wires pass through without any kinks or sharp bends.
- e) Connect the Wires: Inside the junction box, connect the wires using either screw terminals or other appropriate connectors (such as wire nuts or crimp connectors).

Make sure each wire is securely attached and that there is no exposed metal that could cause a short circuit. If necessary, use electrical tape to cover any exposed wire for added protection.

- f) Seal the Junction Box: Close the waterproof junction box, ensuring that the sealing gasket or O-ring is in place to prevent water from entering. Tighten the screws or latches that secure the box.

- g) Test the Connection:

Once the junction box is sealed, test the connection by turning on the power or checking for continuity to ensure everything is connected properly and functioning as expected.

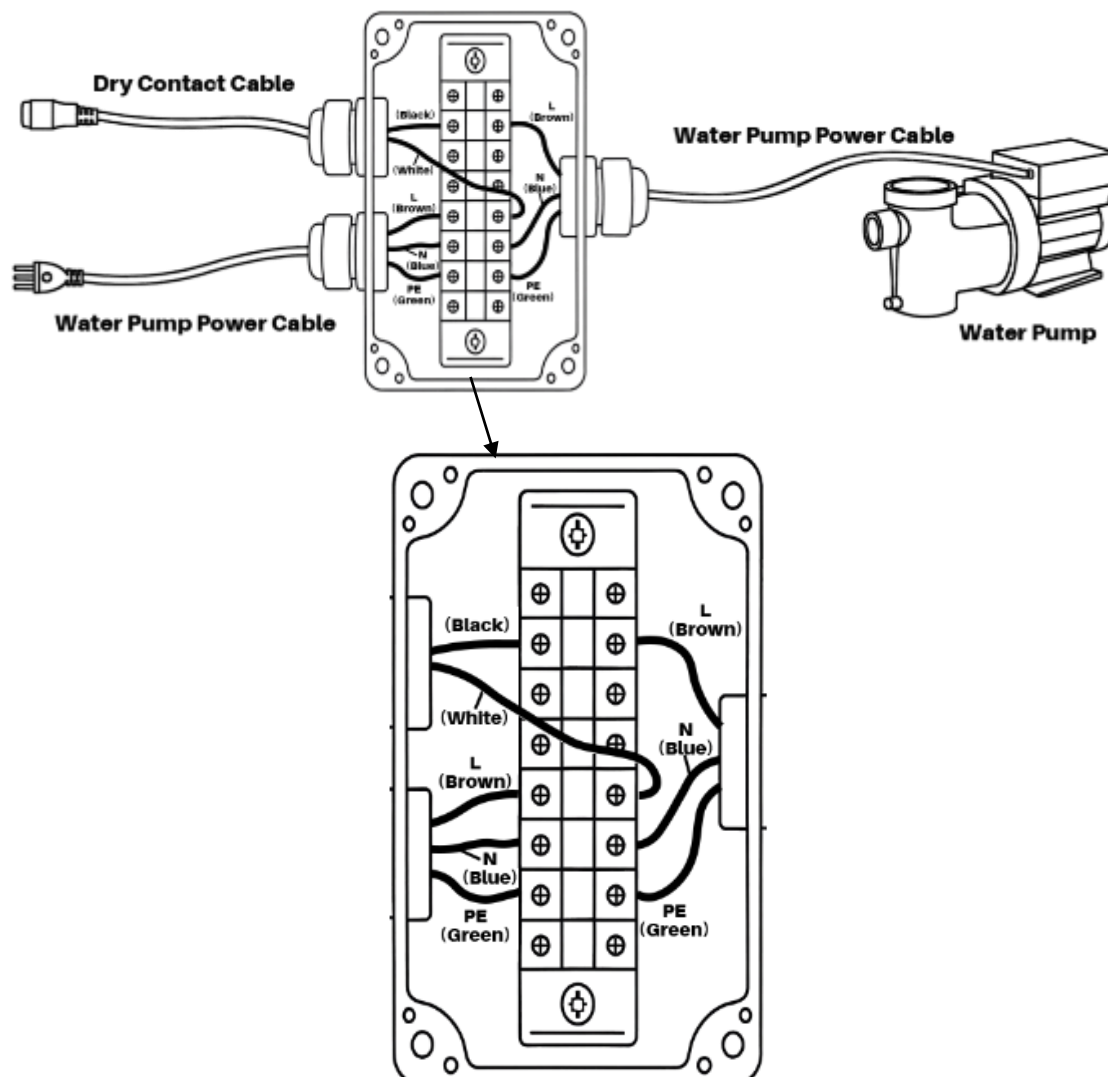

**NOTE:**

- Ensure the power supply is disconnected throughout the entire operation. Only turn on the socket power after all connections have been completed.

### 3.8.4 AUX 1 & 2/ VSP Connector Communication Guide

- Use tools to remove the acquisition board of the host rear cover.

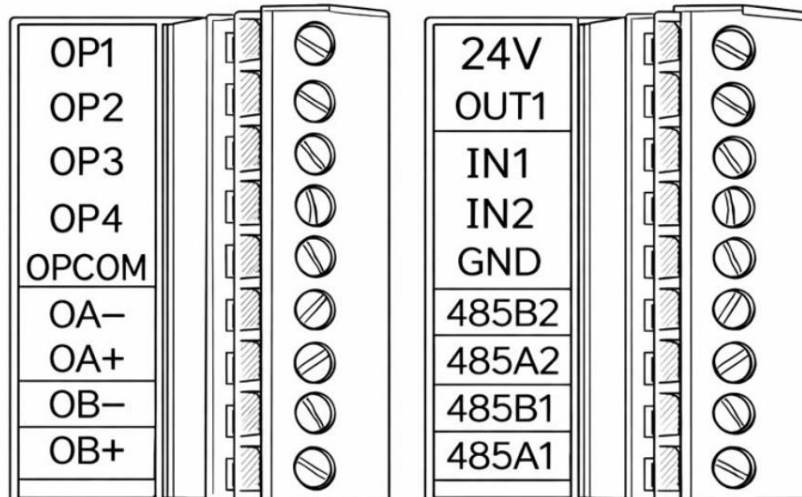

- The connection PCB board shown in the figure. The meaning is as follows:

Item	Connector Description	Remark
<b>OP1</b>	Variable-speed pump control signal	Speed 0 (pump off / icon hidden)
<b>OP2</b>	Variable-speed pump control signal	Speed 1 Control
<b>OP3</b>	Variable-speed pump control signal	Speed 2 Control
<b>OP4</b>	Variable-speed pump control signal	Speed 3 Control
<b>OPCOM</b>	Common terminal	For OP1–OP4
<b>OA-</b>	Output 1 (MAX 10mA, 5V DC)	Negative terminal
<b>OA+</b>		Positive terminal
<b>OB-</b>	Output 2 (MAX 10mA, 5V DC)	Negative terminal
<b>OB+</b>		Positive terminal
<b>24V</b>	24V DC Output	Low Voltage
<b>OUT1</b>	General-purpose NPN output	/
<b>IN1</b>	Pool Cover Signal	Digital input
<b>IN2</b>	Winter mode	Digital input
<b>GND</b>	Ground	For IN1/IN2
<b>485A1/485B1</b>	RS-485 MODBUS communication	Main
<b>485A2/485B2</b>	Reserved RS-485	AUX

# 4 Pool Water Preparation

To prepare the pool water to enable the chlorinator, its chemical composition must be balanced and salt must be added. Certain adjustments to the chemical balance of the pool can take several hours.

The procedure **MUST** therefore be started well **BEFORE** the chlorinator is turned on.

## 4.1 Adding Salt

Add the salt 24 hours before turning on the chlorinator with the pump working. Ensure that the recommended amount of salt is not exceeded.

Measure the salt content 6 to 8 hours after the amount has been added to the swimming pool.

### NOTE:

- If the water in the pool is not fresh and/or if it is liable to contain dissolved metals, use a metal remover, according to the manufacturer's instructions.
- If your water has previously been treated with a product other than chlorine (bromine, hydrogen peroxide, PHMB, etc.), neutralize this product or replace all the water in the pool.
- If using mineral salt (Magnesium chloride and / or Potassium chloride) add approx. 1.4times the amount of normal salt.
- If your water is supplied from a well, shock chlorination with trichloroisocyanuric acid (2 kg/50 m<sup>3</sup> of water).

## 4.2 Chemical Water Balance

The water must be balanced manually **BEFORE** the device is started up.







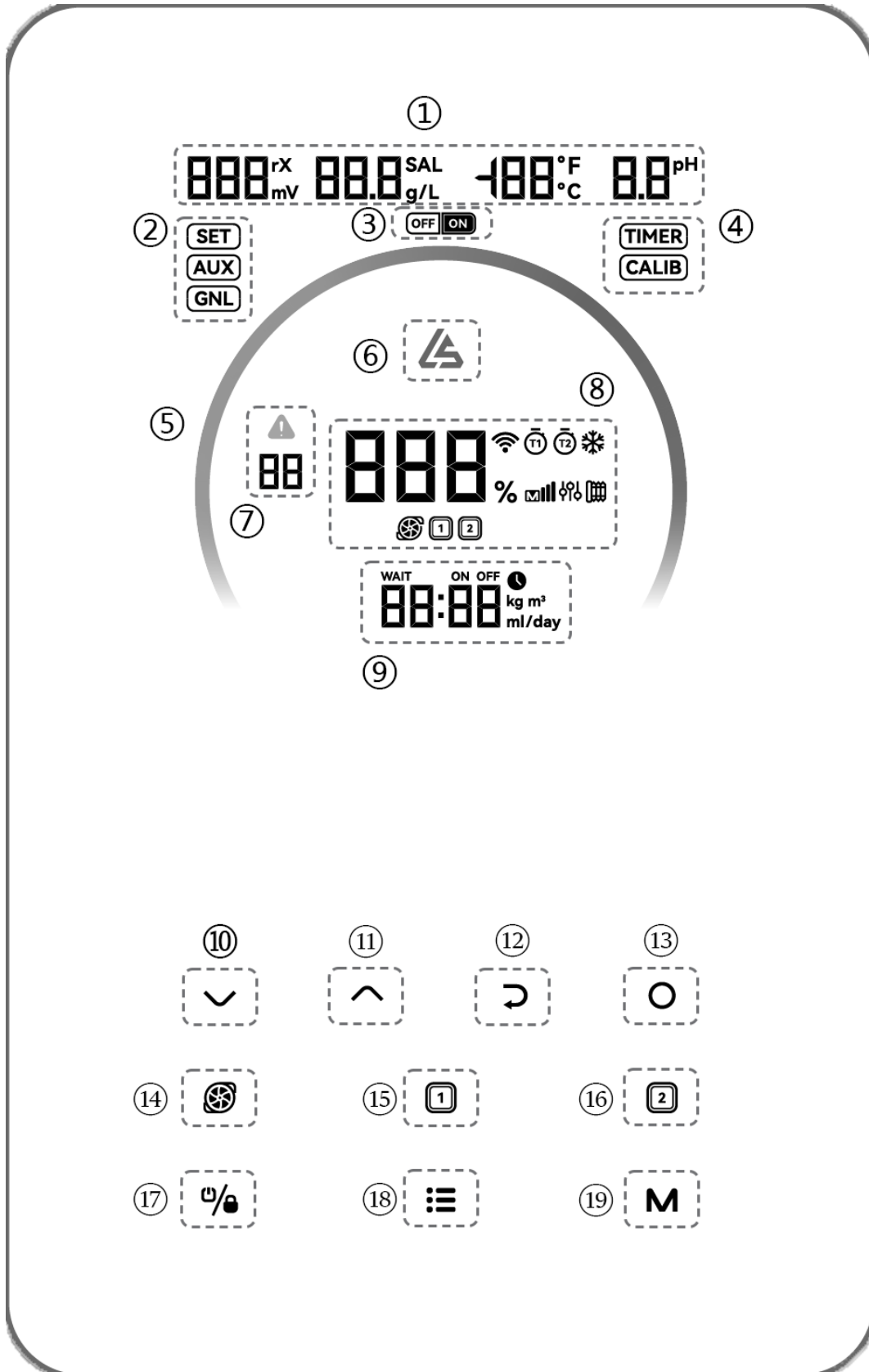

The following table summarizes the concentrations recommended. Your water should be checked regularly to maintain these concentrations and minimize surface corrosion or deterioration.











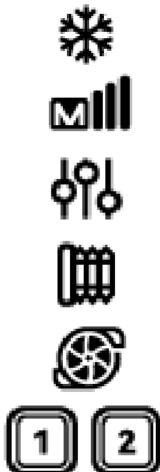

CHEMISTRY	Recommended CONCENTRATIONS
Salt	1-2g/L (recommended 1g/L)
Free chlorine	Free chlorine 1.0 to 3.0 ppm
pH	pH 7.2 to 7.6
Cyanuric acid (Stabilizer)	20 to 30 ppm max, 0 ppm in indoor pool (Add stabilizer only if necessary)
Total alkalinity	80 to 120 ppm
Water hardness	200 to 300 ppm
Metals	0 ppm
Algaecide	Use of algaecide is an option, but must be copper free

# 5 Control Unit Operation

## 5.1 General Screen View



Marked Area	Description	Icon
①	<ul style="list-style-type: none"> <li>● Real-time salinity display</li> <li>● Real-time ORP value *display “---” when the value exceeds 999mV* When ORP &lt; 600, the ORP number will blink.</li> <li>● Real-time water temperature (°C/°F)</li> <li>● Real-time pH</li> </ul> <p>* When pH &lt;6.5 or pH&gt; 8, the pH number will blink.</p>	
②	<ul style="list-style-type: none"> <li>● Setting menu icon</li> <li>● External control enable menu icon</li> <li>● General settings menu icon</li> </ul>	
③	Menu option enable switch icon	
④	<ul style="list-style-type: none"> <li>● Timer</li> <li>● Calibration</li> </ul>	
⑤	<p>LED Indicator</p> <p>*Water quality: PERFECT(Blue light)/GOOD(Purple light)/WAIT(Red light)</p> <p>*OTA updating progress.</p> <p>*Only available with ORP probe and pH/Temp probe.</p> <p><b>Note:</b></p> <p>*Perfect: perfect water quality</p> <p>*Good: water quality close to the setting points</p> <p>*Wait: wait for disinfection</p>	
⑥	Low salt prompt: when the salinity is lower than 1500ppm, the icon lights up.	
⑦	Warnings Error codes	
⑧	<ul style="list-style-type: none"> <li>● Real-time electrolysis rate percentage value or OTA upgrade progress percentage value</li> <li>● WIFI icon. The icon flashes when configuring the network and lights up when connected to the network.</li> <li>● Local time, chlorinator timer 1 and 2</li> <li>● Winter icon. When the water</li> </ul>	

	<p>temperature sensor detects that the temperature is below 10°C, this icon</p> <ul style="list-style-type: none"> <li>● Low / Medium / High Mode</li> <li>● Manual Mode</li> <li>● Pool cover icon. This icon lights up when a valid pool cover signal is detected</li> <li>● Variable frequency water pump icon [VSP]</li> <li>● External Devices 1&amp;2</li> </ul>	
⑨	<p>Main display area:</p> <ul style="list-style-type: none"> <li>● pool volume (m<sup>3</sup>)</li> <li>● turbo mode countdown</li> <li>● acid adding amount (ml/d)</li> <li>● real-time chlorine production (%)</li> <li>● Real time salt amount (kg) - Only show up when A2 on</li> </ul>	
⑩	Tuning down	
⑪	Tuning up	
⑫	Back	
⑬	OK	
⑭	Variable frequency water pump button [VSP]	
⑮	External device 1 button [1]	
⑯	External device 2 button [2]	
⑰	Power/Lock Switch	
⑱	Settings	
⑲	Turbo Mode Switch	

## 5.2 Chlorine Production Mode Introduction

The chlorinator can be configured to 3 different types according to different chlorine production modes.

Configuration		Premium Model	Medium Model	Basic Model
Hardware Options		ORP+pH+Doser	pH+Doser	Doser (optional)
Selectable Chlorine Production Mode	Inverter Mode	√	-	-
	Auto pH Mode	-	√	-
	Manual Mode	√	√	√

The HOME screen of each chlorine production mode is shown as follows:

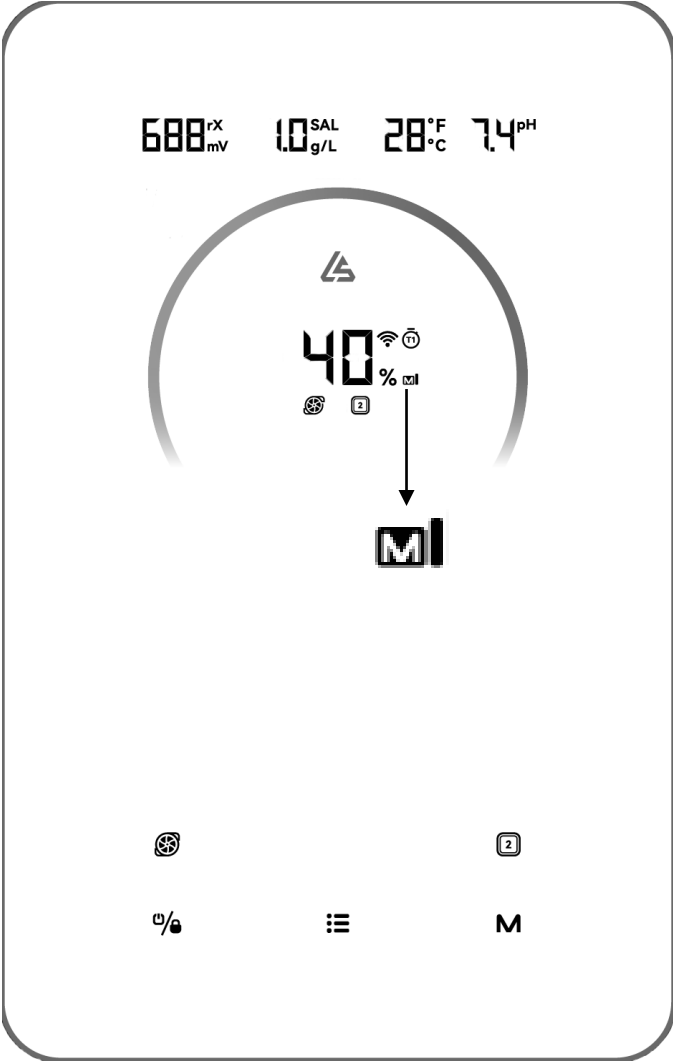

Low Mode

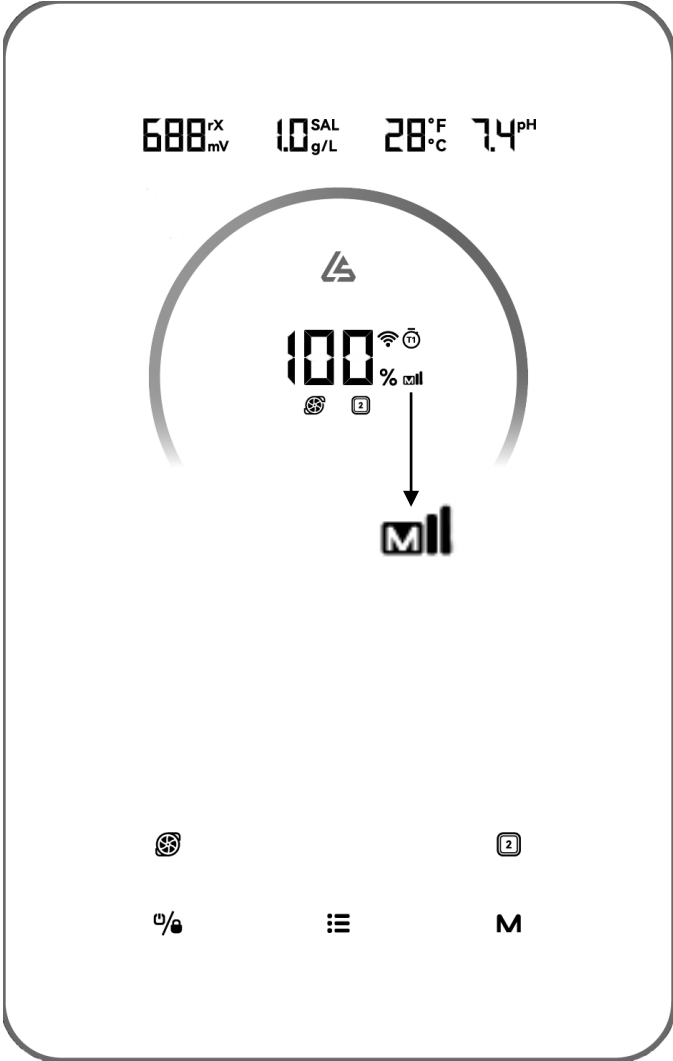

Medium Mode

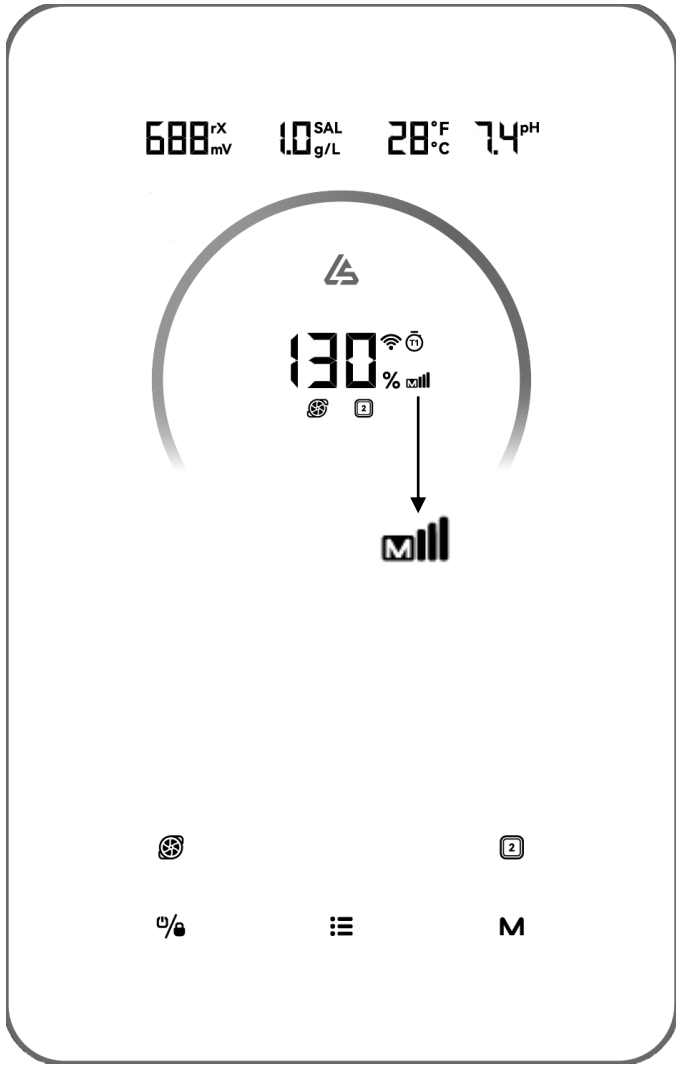

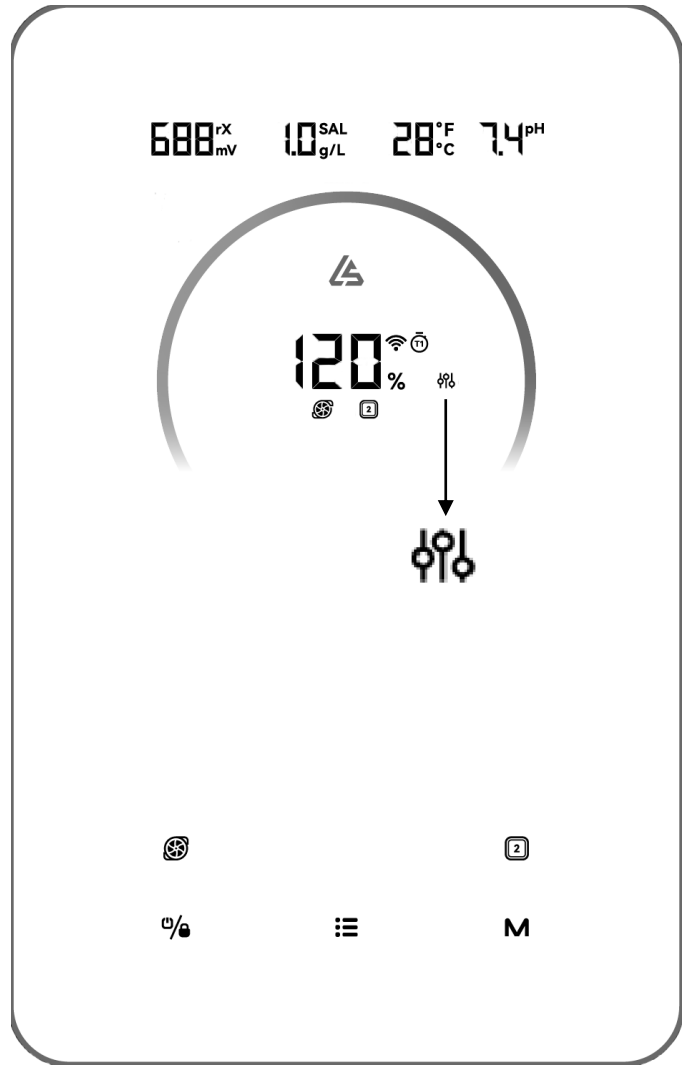

High Mode







Manual Mode

## 5.3 LED Indicator Introduction

The LED Indicator of each status is shown as follows:

Status		LED Indicator
Real-time Water quality Display	Water Quality (Premium Model)	<p>During the electrolysis process, the Circle LED displays an animated effect. During non-electrolysis periods, the Circle LED remains static.</p> <p>The range of the Circle LED display indicates water quality:</p> <p><b>Wait:</b> Circle LED lights up <b>4/6</b> of the ring.</p>  <p><b>Good:</b> Circle LED lights up <b>5/6</b> of the ring.</p>  <p><b>Perfect:</b> Circle LED lights up <b>100%</b> of the ring.</p> 
	1.Unstable water condition 2.Abnormal ORP or pH value <small>* Only available with ORP probe or pH/Temp probe</small>	1.The circular LED light ring does not illuminate fully. 2.A warning indicator or error code will light up.
<b>System Settings (P0-P4)</b>		1. Choose the options type that system settings . 2.Please turn to <b>Pt 5.5.2</b>
<b>Calibration</b>	1. pH Calibration 2. ORP Calibration	<b>1. In operation:</b> 1/6 of the circular LED ring illuminates <b>2.Success:</b> The light bar indicates calibration progress; full illumination indicates calibration is complete
<b>Wi-Fi</b>	Wi-Fi Connection	1. <b>Connecting:</b> WI-FI Icon flashes 2. <b>Completed:</b> WI-FI Icon lights up
<b>OTA</b>	OTA updating progress.	The upgrade progress percentage will be displayed in real time





## 5.4 Basic Commands and Functions

Command Keys	Function
	<ol style="list-style-type: none"> <li><b>Power ON:</b> Hold for 3 seconds initially</li> <li><b>Power OFF:</b> Tap on home screen</li> <li><b>Lock/Unlock:</b> Hold for 3 seconds</li> </ol> <p><b>Note:</b> The auto lock function will be activated after 2 minutes without any operation</p>
	<ol style="list-style-type: none"> <li><b>Activate TURBO mode:</b> Hold for 3 seconds</li> <li><b>Exit TURBO mode:</b> Hold for 3 seconds</li> </ol>
	<ol style="list-style-type: none"> <li><b>Enter the menu:</b> Tap</li> <li><b>Back to home screen:</b> Hold for 3 seconds</li> </ol>
	<ol style="list-style-type: none"> <li><b>Apply/ Go to next step:</b> Tap</li> </ol>

### 5.4.1 Start Up





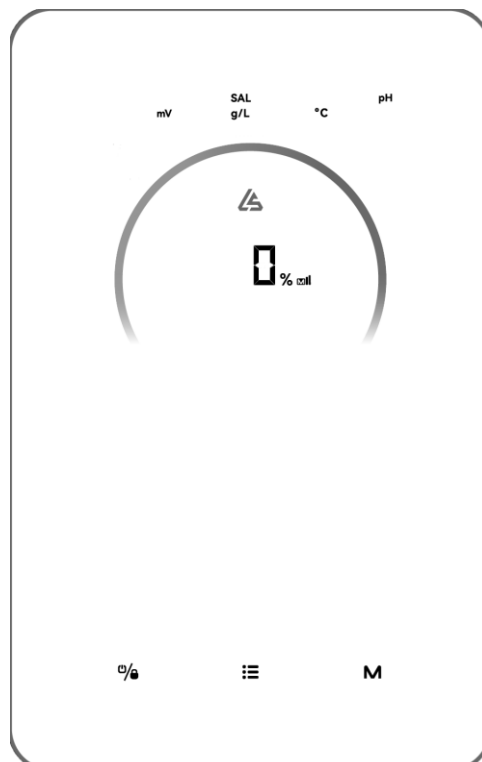

After the first power-on, it is recommended to set the following.

#### ① Chlorine Production Mode Selection

- Hold  for 3 seconds to Power on;
- Tap  to select chlorine production modes;
-  /  shows the current mode;



## ② pH 7.0 and pH 10.0 Calibration (Premium/Medium)

- When the digit display “pH 7.0” and the circle indicator is flashing on the pad screen, place pH probe into the PH7.0 buffer solution. Make sure the head of the probe is totally immersed.
- Calibration is completed when the beeper sounds and the circle vanishes.
- Tap , use  or  to select **CALIB**, Tap  to confirm and see the pH value flashing.
- Use  or  to adjust the pH. Place the pH probe into the corresponding calibration solution.pH 10.0 calibration. (Remember to clean the pH probe before pH10.0 calibration).
- The entire process of pH 10.0 calibration is the same with pH 7.0 calibration.
- Tap  to apply.



### NOTE:



- If the pH probe stayed unsoaked by the buffer solution within 30 seconds or soaked in wrong solution, the LED indicator would keep blinking red until the probe is handled properly.
- Before calibrating or replacing the probe, the valve of the electrolytic cell needs to be turned off to avoid leakage.
- The Default pH Calibration Mode is “pH 7 and pH 10”, you can choose different pH Calibration Mode refer to your Calibration solution type. **(Pt 5.5.3)**

### ③ ORP Calibration (Premium)

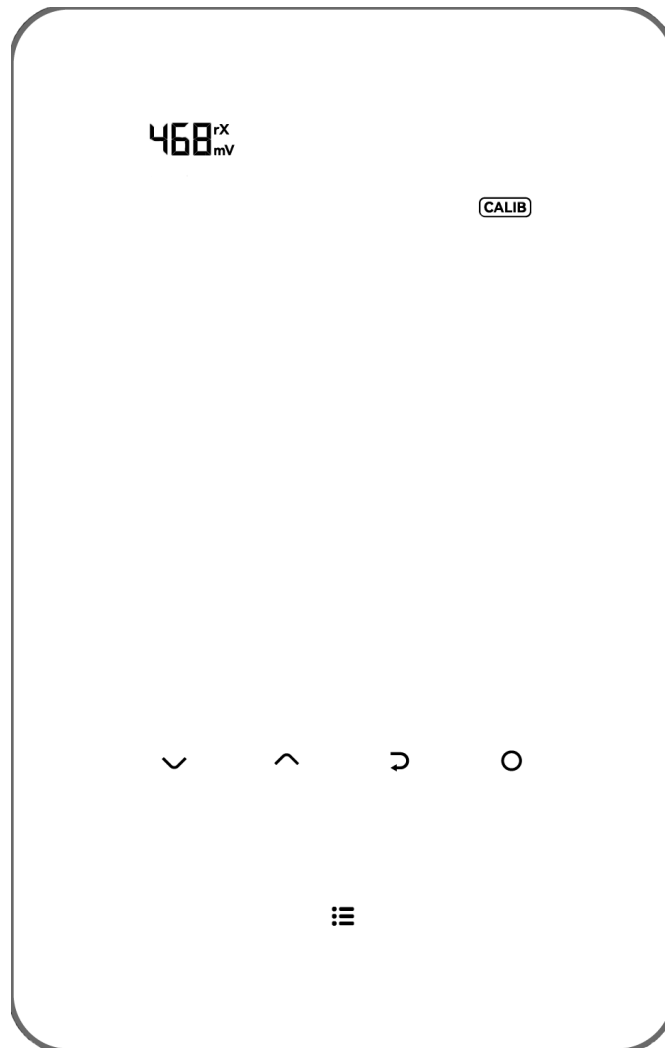









- When the default digit display “ORP 468 mV” and the circle indicator is flashing on the screen.
- Place ORP probe into 468mV buffer solution, make sure the head of the probe is totally immersed.
- Calibration is completed when the beeper sounds and the circle vanishes.
- Tap  to apply.



#### NOTE:





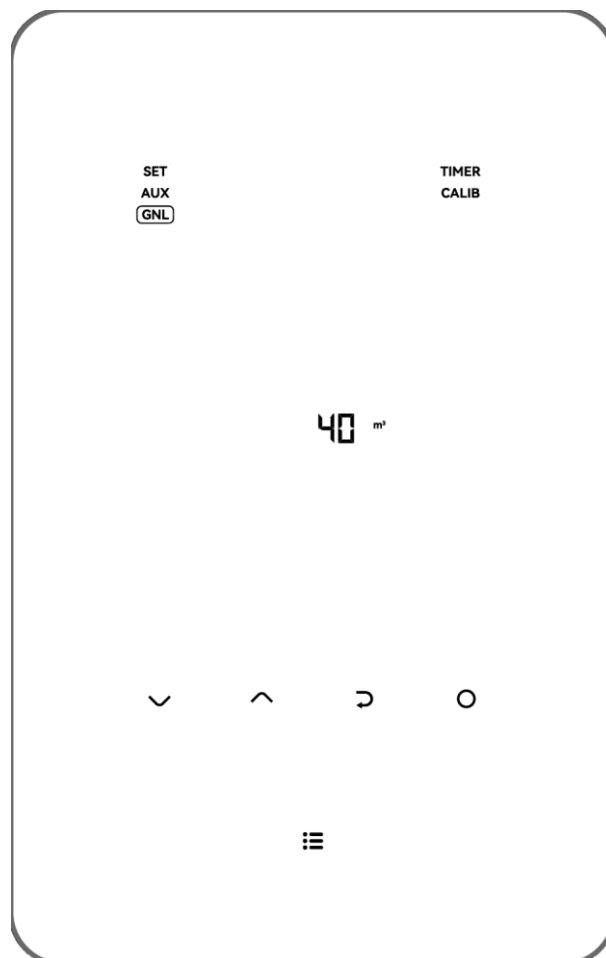

- ORP calibration values range from 200-600mv, step size is 1, hold the  or  button can accelerate the tuning speed.
- This step can also be skipped by tapping .
- If the ORP probe stays unsoaked by the buffer solution for 30 seconds or is soaked in the wrong solution, the circle indicator will keep flashing until the probe is handled properly.

#### ④ Pool Volume Setting







- Tap , use  or  to select , Tap  enter. Then use  or  to select the pool size.
- The default digit display on the pad screen is “SIZE 40 m<sup>3</sup>” as follows.
- When the number is blinking, it can be turned from 0 to 150 m<sup>3</sup>, in increments of 5, by tapping  or . Hold the button can accelerate the tuning speed.
- Tap  to apply.











### ⑤ Local Time Setting

- Tap , use  or  to select **GNL**, Tap  enter. Then use  or  to select the Time Setting.
- Tap  to apply.









### ⑥ Polarity Reversal Interval Setting

- Tap , use  or  to select **GNL**, Tap  enter. Then use  or  to select the Polarity Reversal Interval Setting.
- Tap  to apply.









### ⑦ pH Setpoint Setting (Premium/Medium)

- Tap , use  or  to select **SET**, Tap  enter. Then use  or  to select the pH Setpoint Setting.
- The default digit display on the pad screen is “7.2”.
- When the number “7.2” is blinking, it can be turned from 6.5 to 8.5, in increments of 0.1, by tapping  or . Hold the button can accelerate the tuning speed.
- Tap  to apply.

### ⑧ ORP Setpoint Setting (Premium)

- Tap , use  or  to select **SET**, Tap  enter. Then use  or  to select the ORP Setpoint Setting.
- The default digit display on the pad screen is “700mV”.
- When the number “700” is blinking, it can be turned from 200 to 850 mV, in increments of 10, by tapping  or . Hold the button can accelerate the tuning speed.
- Tap  to apply.









## ⑨ Chlorine Production (Manual Mode)

- Tap **M** to select Manual Mode
- Tap , use  or  to select **SET**, Tap  enter. Then use  or  to select the Chlorine Production.
- default digit display on the pad screen is “100%”.
- When the number is blinking, it can be turned from 130 to 0, in increments of 5, by tapping  or . Hold the button can accelerate the tuning speed.
- Tap  to apply.





















### Note:

- 1) In Manual mode without a timer, if electrolysis is on for more than 24 hours, it will automatically **shut down**, requiring to reset the electrolysis percentage before it can resume.
- 2) If the electrolysis percentage in Manual mode is set to less than 10%, there is no 24-hour limit for chlorine production to stop.

















## ⑩ pH Dosing Volume Setting (Manual Mode)

- Tap **M** to select Manual Mode
- Tap , use  or  to select **SET**, Tap  enter. Then use  or  to select the pH Dosing Volume Setting.
- pH Dosing Volume Setting: range 0-99900ml/d
- The digit display on the pad screen is “0-9990”
- The default digit display on the pad screen is “60”, it means the real pH Dosing Volume is 600 ml/d.
- When the number “50” is blinking, it can be turned from 0 to 9990, in increments of 10, by tapping  or . Hold the button can accelerate the tuning speed.
- Tap  to apply.

















## ⑪ External Control Enable Settings

- Tap , use  or  to select **AUX**, Tap  enter. Then use  or  to select the icon for enabling external control.
- When  /  /  lights up, Tap  to confirm, then use  or  to select **ON** / **OFF**. Tap  to apply.
- When **ON** is selected, the  /  /  button will appear on the home screen; when **OFF** is selected, the  /  /  button will disappear.
- Tap  to Confirm Timers setting and return to home screen.













## ⑫ Timers Setting (Power ON/OFF)

- Tap , use  or  to select **TIMER**, Tap  enter. Then use  or  to select the Timers.
- When  lights up, Tap  enter, or use  or  to select .
- When **ON** lights up, Tap , then use  or  to finished timers setting.
- When **OFF** lights up, Tap  to turn off the timers setting.
- Tap  to Confirm Timers setting and return to home screen.













### ⑬ VSP (Timer)

- After starting up, the variable speed pump can be used.
- Tap , use  or  to select **TIMER**, Tap  enter. Then use  or  to select the VSP .
- Tap , use  or  to select the variable speed pump timer (01-04).
- Tap , use  or  to select variable speed pump speed levels (SP1/SP2/SP3/OFF).
- use  or  to set start and end times.
- Tap  to apply.

### ⑭ AUX1 (Timer)





- External Device 1 is connected.
- Tap , use  or  to select **TIMER**, Tap  enter. Then use  or  to select the AUX1 .
- Tap , use  or  to select the 01/02 timer.
- use  or  to set start and end times.
- Tap  to apply.

### ⑮ AUX2 (Timer)

- External Device 2 is connected.
- Tap , use  or  to select **TIMER**, Tap  enter. Then use  or  to select the AUX2 .
- Tap , use  or  to select the 01/02 timer.
- use  or  to set start and end times.
- Tap  to apply.

### ⑯ Doser Check (optional)

To check the Doser works properly or not, the steps are as follows:

- Make sure the Doser hoses and PE acid tubes are connected and fitted tightly.
- Check the acid tank's fluid level, make sure PE acid tube is connected to suction valve in the tank.
- Tap , turn off the Chlorinator(**Power OFF**).
- Hold the place of  and  for 3 seconds, the Doser will rotate for 30s, to check its rotation.
- Repeat last step 2-3 times, until the acid solution is fulfilled in PE acid tubes and peristaltic tube.
- Acid solution is pushed out to pool water through the Doser tube, the Doser is ready.
- Tap , turn on the Chlorinator(**Power ON**).

## 5.4.2 TURBO Performance

- ① Switch ON: In unlocked state, press and hold **M** for 3 seconds to enter turbo mode, the device will run at 130% power for 24 hours regardless of the ORP readings and/or setpoint values. The real-time production and turbo countdown will be displayed.
- ② Switch OFF: Hold **M** for 3 seconds.

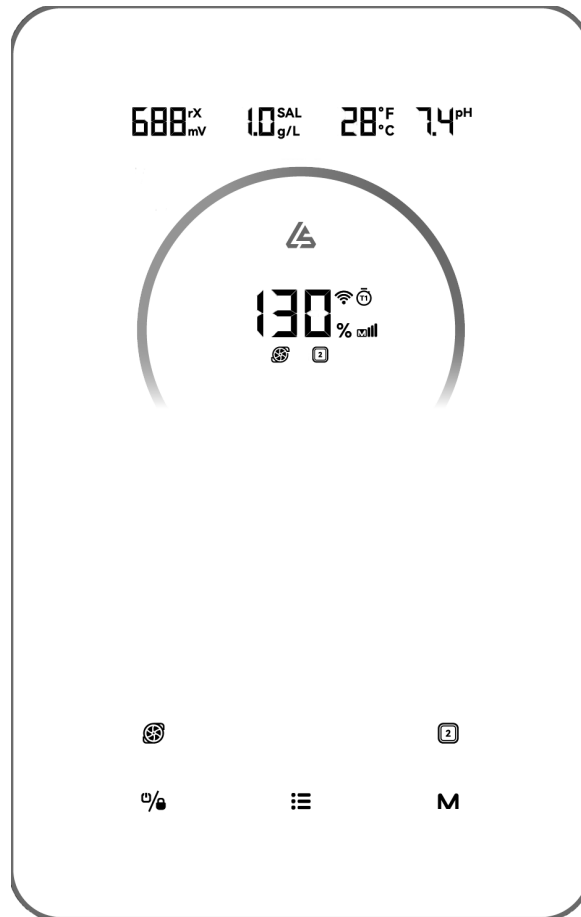

Operating Speed Display

### NOTE:



- TURBO mode is suggested to be activated when chlorine is urgently needed.
- TURBO mode cannot be activated When  lights up.
- If the chlorinator is powered off with TURBO mode turned on, the TURBO countdown refreshes when the chlorinator is turned on again.
- When the TURBO mode terminates or stops, production continues according to the preset settings (Inverter/Auto pH/Manual).

### 5.4.3 Recommended Settings

Tap Setting  to enter settings in accordance with following order:





- 1) pH Target Setting: range 6.5-8.5, the recommended setpoint is in:7.2-7.6
- 2) ORP Target Value setting: range 200-850mV (Inverter Mode)
  - Suggested ORP Winter setting: ORP 650mV.
  - Suggested ORP summer setting: ORP 700mV.
  - If you have other free chlorine monitoring instrument., adjust your pool water (Free chlorine 1.0 to 3.0 ppm), then look at ORP value on the chlorinator screen and memorize this level as the setpoint.
- 3) Chlorine Production: range 0-130% (Auto pH Mode / Manual Mode);
- 4) pH Dosing Volume Setting: range 0-99900 ml/d (Only Manual Mode)  
Hydrochloric Acid: ≤12.5% concentration;
- 5) Timers setting: range 0:00-24:00 (24h-clock);

### 5.4.4 Calibration







Tap  select **CALIB** and when it flashes, Tap  to enter calibration mode in accordance with following order:

- 1) pH 7.0 and 10.0 Calibration (Inverter Mode / Auto pH Mode)
- 2) ORP Calibration (Inverter Mode)
- 3) Pool volume setting: range 0-150m<sup>3</sup>,
- 4) Local time setting: range 00:00-24:00 (24h-clock),
- 5) Tap  to return home screen.



#### NOTE:

- During the settings and calibration process, all values are set by tapping  and  ;
- Users can return to home screen at any point by holding  for 3 seconds or skip any step by tapping  .
- The Default pH Calibration Mode is “pH 7 and pH 10”, you can choose different PH Calibration Mode refer to your Calibration solution type. **(Pt 5.5.3)**

## 5.5 Combinations and Operation

Combinations	Function
Tap  , then hold  and  for 3 seconds	Enter network configuration screen
With the power off, then hold the place of  and  for 3 seconds	pH Doser self-test 30 seconds
With the power off, hold  and <b>M</b>	Enter full-display mode, and all elements on the LCD screen will light up.

### 5.5.1 Chlorine Mode Selection

Tap **M** to select chlorine production modes  /  ;

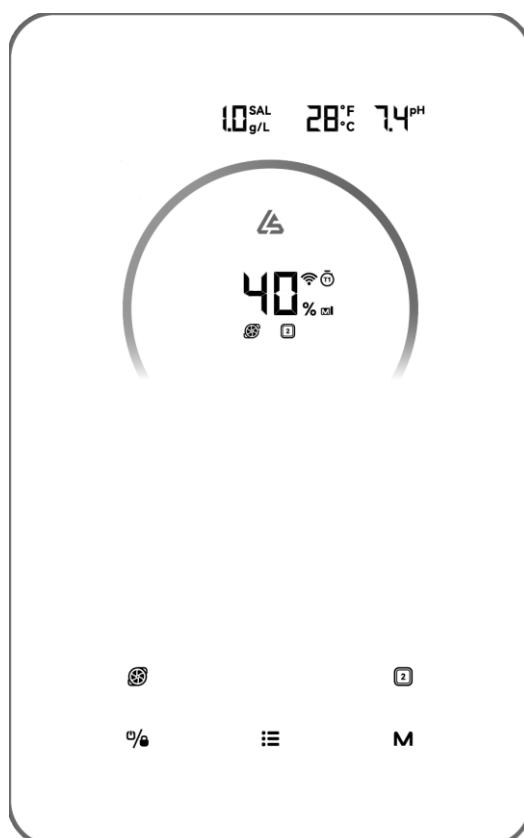



Tap **M** to choose chlorine production mode, according to different hardware options shown in Sec. 5.2.

## 5.5.2 System Settings (P0-PA)

In home screen, Tap , turn off the Chlorinator(**Power OFF**).



Then hold  to enter Screen at Power OFF.

Tap  or  to choose the system settings (**P0-PA**) .

Then tap  to save and return home screen (**Power OFF**).

Function Code	Function Name	Setting Value	Meaning	Description
P0	Probe Calibration Reminder Enable	OFF	Disables the probe calibration reminder.	When disabled, the system will not display the A5 warning.
		ON	Enables the probe calibration reminder.	
P1	pH Calibration Options	1	pH 4.0 and pH 7.0	If changed, recalibrate the pH probe using the corresponding standard buffer solutions. Note: When calibrating at pH 9.18, the display will show 9.2.
		2	pH 4.0 and pH 9.18	
		3	pH 4.0 and pH 10.0	
		4	pH 7.0 and pH 9.18	
		5	pH 7.0 and pH 10.0 (default)	
P2	Temperature Unit	°C (0)	Displays salt concentration in Celsius.	
		°F (1)	Displays salt concentration in Fahrenheit.	
P3	Modbus Address	1–28	Modbus node address.	Default value: 8. Setting changes take effect after restart.
P4	Modbus Baud Rate	1	4800	Setting changes take effect after restart.
		2	9600 (Default)	
		3	19200	
P5	E2: pH setpoint not reached	0,1	0: Off 1: On (Default)	
P6	EA: ORP setpoint not reached	0,1	0: Off (Default) 1: On	
P7	A1: ACID TANK	0,1	0: Off 1: On (Default)	
P8	A2: ADD SALT	0,1	0: Off 1: On (Default)	
P9	A5: Probe Calibration (180days)	0,1	0: Off (Default) 1: On	It is very important to carry out a calibration of the probe at the beginning of each season, or after probe replacement.
PA	Pool cover protection	0-30%	30% (default)	

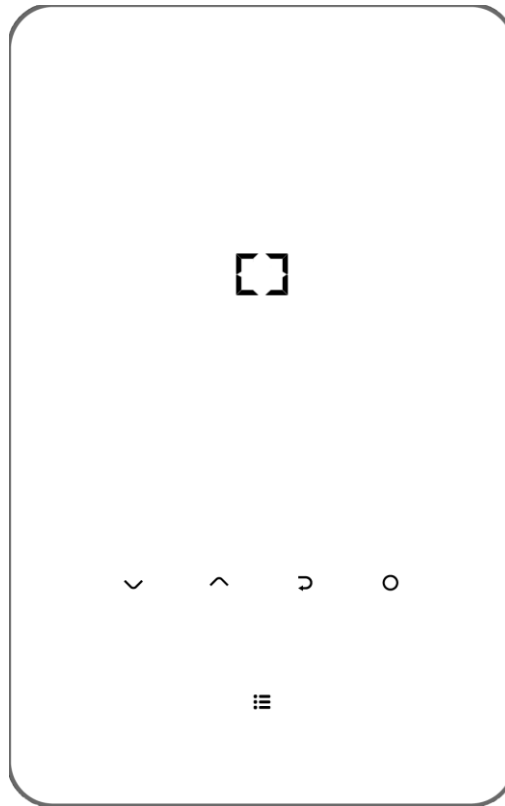

### 5.5.3 Restore Factory Settings

Hold  for 3 second on home screen, then tap , the chlorinator is restored to factory settings.



Parameter	Default	Related Mode
pH Setpoint	7.2	Inverter, Auto pH
ORP Setpoint	700mv	Inverter
Chlorine Production	100%	Manual
pH Dosing Volume	60	Manual
Chlorinator Timer 1 and 2	00: 00 – 00: 00	
Vs Pump Timer 1, 2, 3 and 4	00: 00 – 00: 00	
AUX1 Timer 1 and 2	00: 00 – 00: 00	
AUX2 Timer 1 and 2	00: 00 – 00: 00	
	4h	
System Setting	Default	Related Mode
【P0】 ORP calibration values	468	Inverter
【P1】 pH Calibration Mode	5: PH7.0、 PH10	Inverter, Auto pH
【P2】 Temperature Unit	°C	
【P3】 Modbus Address	8	
【P4】 Modbus Baud Rate	9600	
【P5】 E2: pH setpoint not reached	1	Inverter, Auto pH
【P6】 EA: ORP setpoint not reached	0	Inverter, Auto pH
【P7】 A1: ACID TANK	1	Inverter, Auto pH
【P8】 A2: ADD SALT	1	
【P9】 A5: Reminder for Probe Calibration (Each 180days)	0	Inverter, Auto pH
【PA】 Pool cover protection	30%	

## 5.5.4 Network Configuration

- ① Enter Network Configuration screen by tapping , then hold  and  simultaneously for 3 seconds, an intermittent buzz will be heard.
- ② During network configuration process, the chlorinator remains operating with the previous configuration.
- ③ The beeper stops when network configuration is complete.

## 6 Salt Replenishment

 **The chlorinator must remain OFF during this operation and until the additive is completely dissolved. Operating the chlorinator with non-dissolved salt could irreversibly damage the cell and the power supply, and lead to a void of the warranty.**

Calculate the volume of the swimming pool and add 1.5 to 3 Kg of salt per cubic meter. The suggested salinity is 1.5-3 g/L. Make sure the chlorinator is disconnected during the whole salt adding process, and turn on the filtration system for at least 24 hours, allowing the salt to dissolve completely.

 **For any new pool builds please wait for four weeks before adding salt into any recently cement coated pool or discuss this with your pool builder.**

The salt dissolving process can be accelerated using the pool cleaner. Check the salt concentration is between 1.5 and 3 kg/m<sup>3</sup> using a kit from a specialized pool shop.

The salt concentration may reduce over time due to rain or other periodic freshwater contributions (topping up, backwashing, etc.). Whenever the salt concentration needs to be corrected, pour salt as close as possible to the return lines. Never pour salt in the skimmers or near the drain inlet.

# 7 Maintenance

## 7.1 Cleaning the Electrodes

The smart polarity inversion system is designed to prevent the electrode plates from corrosion and scaling (Default setting = 4 hours). However, periodic cleaning may be required when the water hardness is too high.

The cleaning process is listed as follows:

- ① Turn off the chlorinator and the filtering, close the isolation valves, and ensure power is disconnected at the isolating switch.
- ② Place the cell backwards and fill it with a cleaning solution so that the electrode plates are immersed. Do not allow the cell cap assembly to be immersed.
- ③ Leave the cleaning solution to dissolve the scale deposit for about 15 minutes. Dispose of the cleaning solution at an approved waste recycling site, never pour into the rainwater drainage system or into the sewers.
- ④ Rinse the electrode using clean water and put it back on the cell fixture collar (there is an alignment mark).
- ⑤ Open the isolation valves and restart the filtering and chlorinator.
- ⑥ If you do not use a commercially available cleaning solution, you can manufacture it yourself by carefully mixing 1 volume of hydrochloric acid with 9 volumes of water (Warning: always pour the acid into the water and not the opposite and wear suitable protective equipment!).
- ⑦ Make sure that the setting of the polarity inversion cycles is adapted to the pool water hardness.

## 7.2 Maintenance of the ORP Probe (Only Premium)

### 7.2.1 Cleaning the Probe

Under any circumstance, every 6 monthly cleaning is always advisable. Generally, impurities and grease caught on electrodes may also result in measurement errors.

The cleaning steps are as follows:

- ① Turn of the chlorinator, close flow isolating valve, and unscrew the ORP probe from the holder.
- ② Thoroughly clean the probe in pure, preferably distilled water. Carefully shake the probe to remove the water. Use a cotton or a paper napkin if necessary.
- ③ Turn on the control unit, Insert the probe into standard calibration solution (default 468mV) and complete the calibration process.
- ④ **It is very important to carry out a calibration of the ORP probe at the beginning of each season of use when returning to service, and after each probe replacement.**

### 7.2.2 Storage

In case of pools being shut down during the winter season, take the probe out of the cell and store it at temperature from +5 to +30 °C in the probe storage cap filled with a storage solution. Other storage methods are not recommended.

**NOTE:** Never leave the probe in the open air. If the probe has been dry for a period of time, it can be regenerated using the standard calibration solution.

## 7.3 Maintenance of the pH Probe (Premium/Medium)

### 7.3.1 Maintenance

It is recommended to clean and check the probe every 6 months. Generally, impurities and grease caught on electrodes may also result in measurement errors.

The cleaning steps are as follows:

- ① Stir the probe in a glass of water in which a spoonful of detergent has been dissolved.
- ② Wash it under the tap and leave it for a few hours in a glass of water in which 1 cm<sup>3</sup> of hydrochloric acid has been added.
- ③ Thoroughly clean the probe in pure, shake the probe to remove the water. Use a cotton or a paper napkin if necessary.
- ④ Recalibrate the probe again.
- ⑤ **It is necessary to carry out a calibration of the pH probe at the beginning of each season of use when returning to service, and after each probe replacement.**

### 7.3.2 Storage

In case of pools being shut down during the winter season, take the probe out of the cell and store it at temperature from +5 to +30 °C in the probe storage bin filled with a storage solution. Other storage methods are not recommended.



#### NOTE:

- If well maintained, a probe can last for two or three years. When the probe is exposed in air, the original cap should be placed, or it should be submerged in a glass of water.
- If a probe has been left to dry, it can be regenerated by leaving it for 12 hours in a glass of water, preferably adding a few drops of hydrochloric acid.

## 7.4 Maintenance of the Doser (Optional)

### 7.4.1 Maintenance

To check the Doser works properly or not, the steps are as follows:

- ① Tap  , turn off the Chlorinator(Power OFF).
- ② Hold the place of  and  for 3 seconds, the Doser will rotate for 30s, to check its rotation and sounds.
- ③ Apply grease on the peristaltic tube if necessary.

#### NOTE:

- **Inverter Mode and Auto PH Mode:** the Doser will regularly rotates every 3 minutes, with 90ml acid injection each rotation (30s duration).
- **Manual Mode:** the Doser will rotate according to **pH Dosing Volume Setting**.

The doser roller will rotate for 30 seconds and injecting around 90ml acid each time. Injection frequency is based on pH dosing volume setting (Default setting: 50ml, 24hours ) and the chlorinator operate time in ever 24hours.

- When the actual pH value is equal to or lower than pH setpoint, the Doser will stop spinning.
- When pH probe detection fails or E3 (no flow) alarm displays, the Doser will stop spinning.

# 8 Winterizing and Low Temp Protection

The chlorinator has low temperature protection to limit chlorine production (%) under poor operating conditions such as cold water (winter).

Active winterizing = filtering and chlorinator operational in winter:

Passive winterizing = lower water level and drained piping: leave the electrode plates dry in its cell with its isolation valves- open.

### Low Temperature Protection:

- Water temp above 10°C: Chlorinator running in the preset mode (Inverter, Auto pH...)
- 5°C < Water temp < 10°C: Chlorinator running, production capped at 30%.
- Water temp below 5°C: Electrolysis off. E5 Alarm is on.
- After E5 Alarm is on, 5°C < Water temp < 10°C, electrolysis keeps off.
- 10°C < Water temp < 12°C: Chlorinator running, capped at 30%, A3 keeps on.
- Water temp > 12°C: A3 off, Chlorinator running in the preset mode.

### Note:

- Temperature sensor must be installed, if you need Low temperature protection.

# 9 Overheat Protection

Overheat protection will be activated when the power pack temperature inside the main control unit is higher or equal to 70 °C.

High Temperature (Power pack)	$70^{\circ}\text{C} \leq \text{Temperature} < 80^{\circ}\text{C}$	A. A4 Electrolytic output limited to 30%
Over Temperature (Power pack)	$\text{Temperature} \geq 80^{\circ}\text{C}$	A. E4 occurred and stop electrolysis B. Temperature < 68°C, A4 off, electrolysis starts again.

# 10 Wi-Fi Instruction and iGarden App

## 10.1 Start-Up

### 10.1.1 Download App on Smartphone

“iGarden” app is available on App Store and Google Play. Please scan the following QR code to download:





## 10.2 Networking Configuration

### 10.2.1 Auto Scan

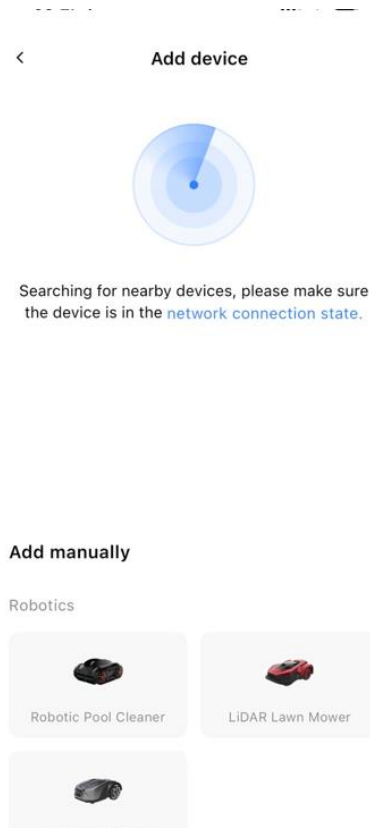
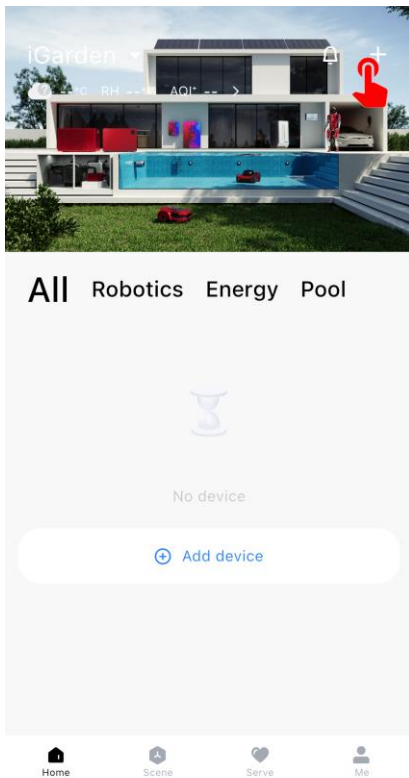
- ① Turn on your local Chlorinator, Wi-Fi device, cell phone Bluetooth.
- ② Enter the “iGarden” App, tap the "+" icon in the top right corner of the home page, and then Tap on "Add Device".



- ③ When chlorinator is on home screen, tap  to enter settings, hold  and  for 3 seconds, when an intermittent beep occurs, and enters network connection mode **【3E】** .
- ④ When your phone finds the chlorinator, it will be displayed on your phone. Tap "Next", enter the wifi password and tap "Next". Then the device will be automatically connected to the App.

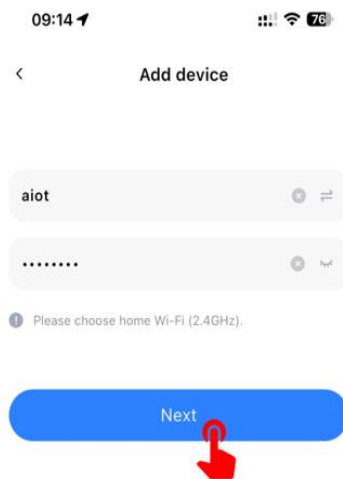
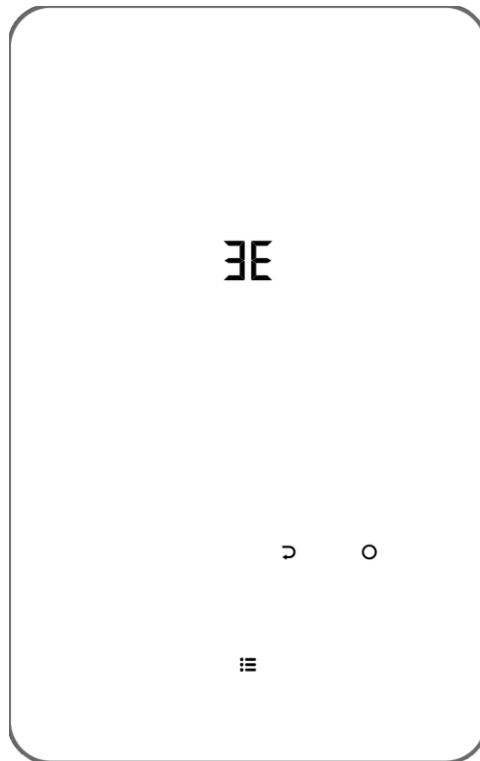

# 10.2.2 Wi Fi hotspot

- ① Turn on your local chlorinator, Wi-Fi device, cell phone Bluetooth.
- ② enter the "iGarden" App, tap the "+" icon in the top right corner of the home page, and then Tap on "Add Device".

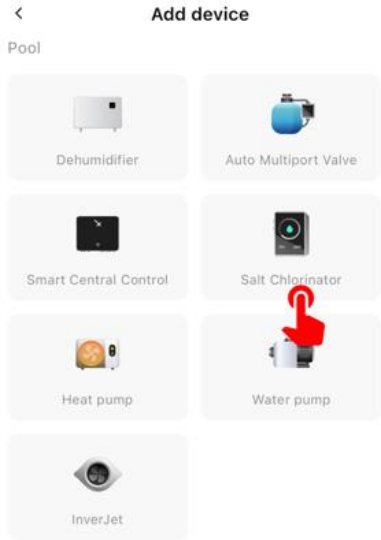
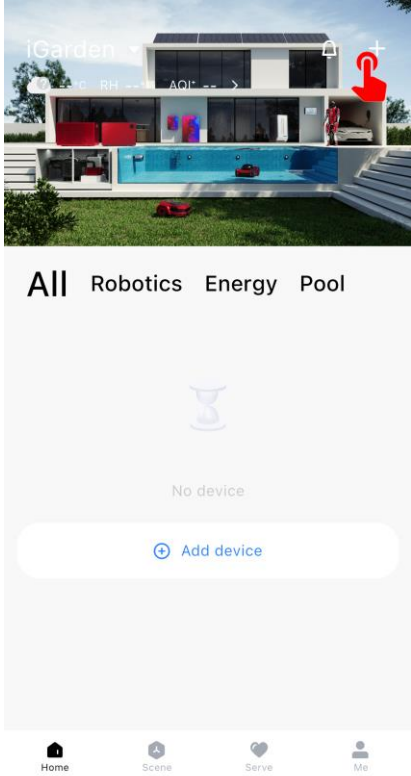

- ③ Enter the home wifi password and tap “Next”,
- ④ When chlorinator is on home screen, tap ☰ to enter settings, hold ☰ and + for 1.5 seconds, when an intermittent beep occurs, and enters network connection mode 【3E】 .
- ⑤ After the chlorinator enter network connection mode 【3E】 , connect your cell phone to the hot spot, as follow:

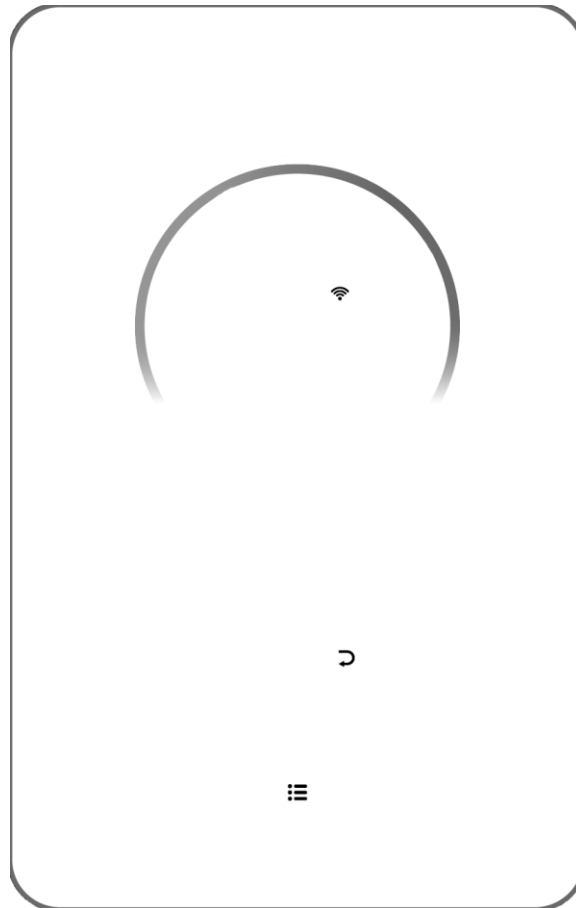

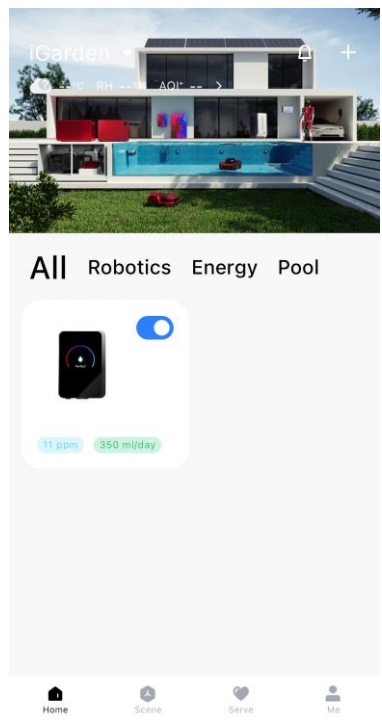
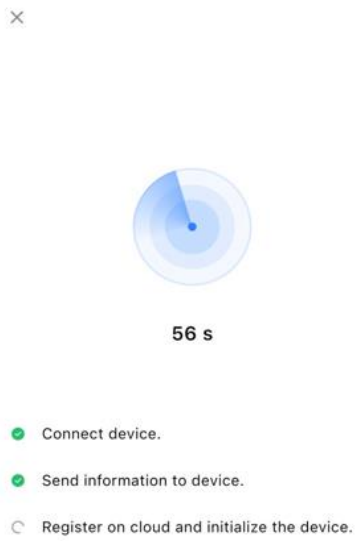
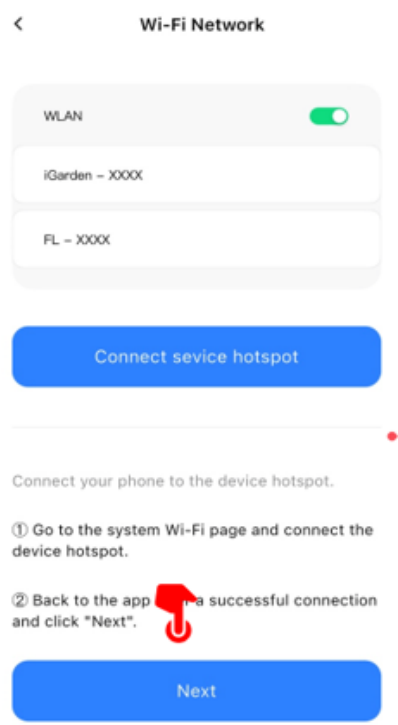
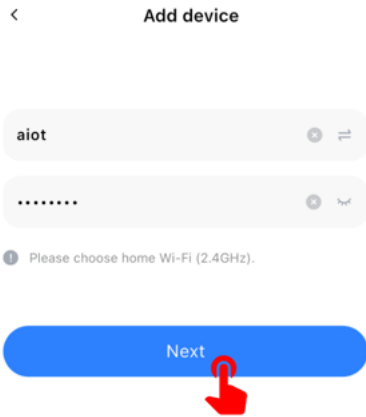

## 10.3 Remove Control

After Networking Configuration :

- ① On iGarden Home screen , user can tap the chlorinator icon enter its main screen. Or switch on/off the chlorinator by the blue slider.
- ② Chlorinator main screen displays real time status parameters and mode. user can adjust seting points, timers and switch to different modes.
- ③ Tap “ ... “on the upper right corner to enter Device details: Device information, external control, pool volume, Salinity calculation, polarity reversal interval, electrode plates life, failure code, remove access.

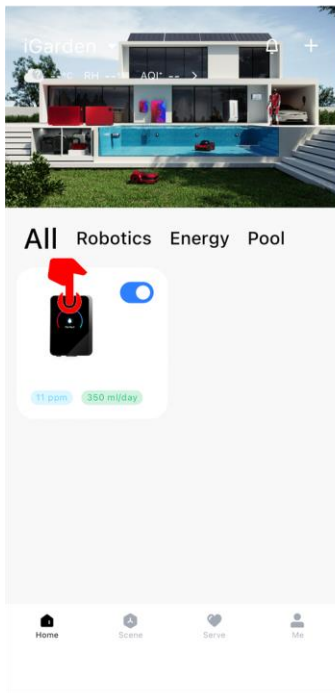

iGarden Home screen

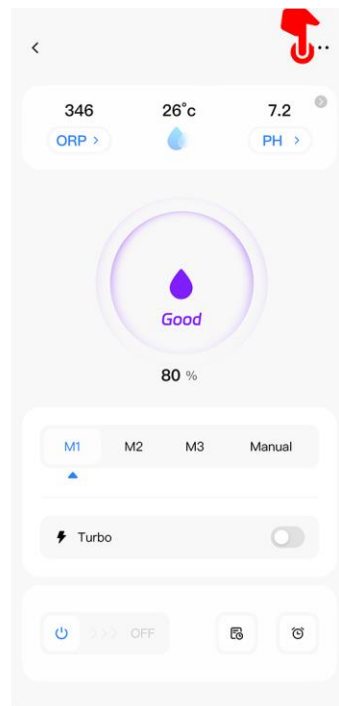

Chlorinator main screen

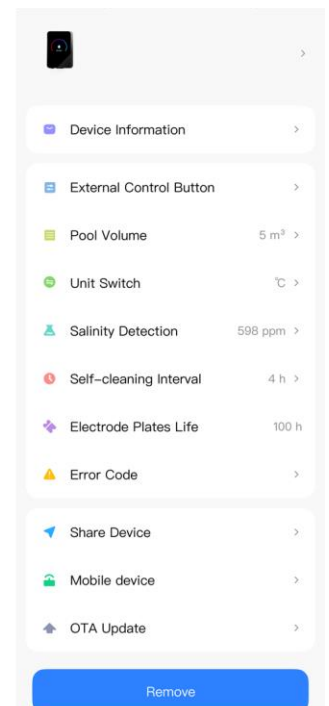

Device details

### 10.3.1 Data History

- ① Enter data history in the chlorinator main screen.
- ② Last 24 hours, 7 days, 14 days, or 30 days data is displayed.
- ③ Tap to the icon  in the upper right corner to enlarge the data table.

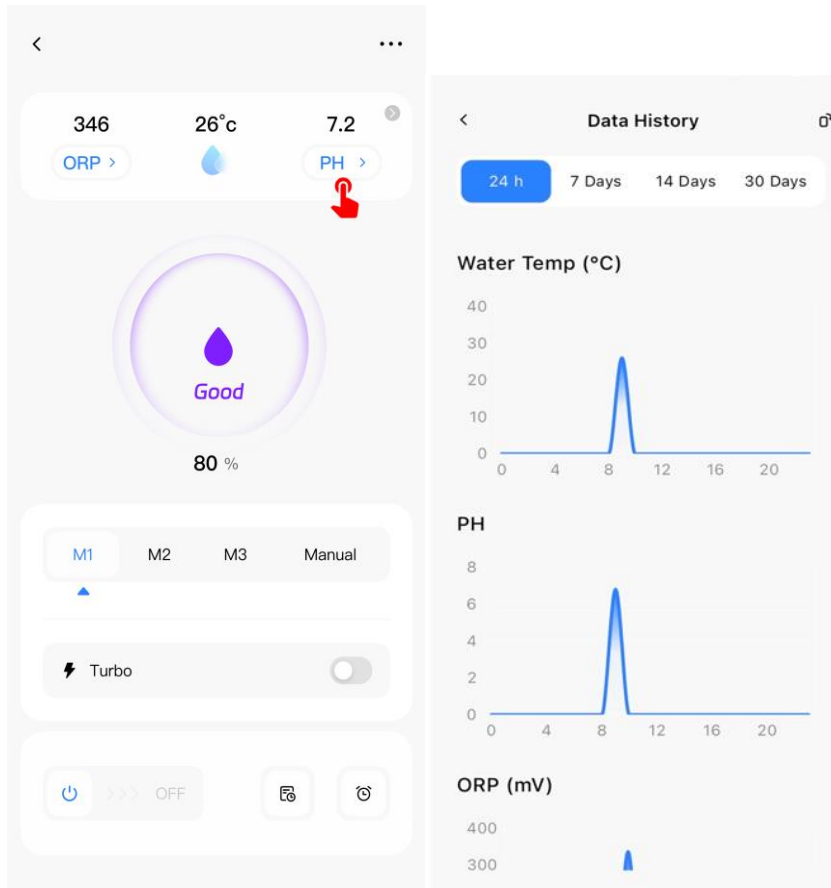

### 10.3.2 Alarm or Error History

- ① Enter alarm or error history in the chlorinator main screen.

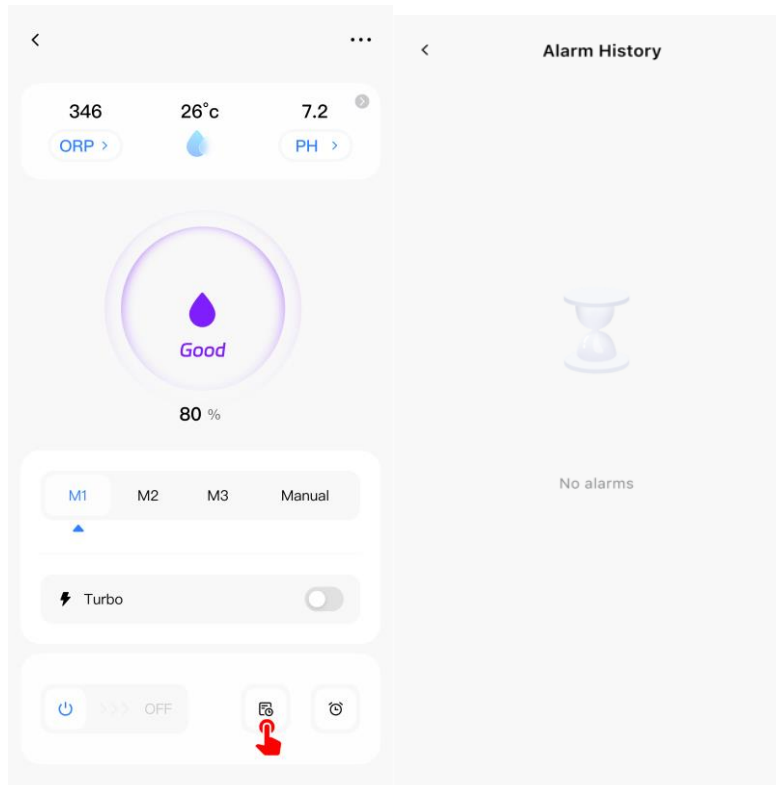

### 10.3.3 Timer Settings

- ① Enter Timer Settings in the chlorinator main screen.
- ② Pure pro timers includes: 2 chlorinator timers, 6 variable speed pump timers.

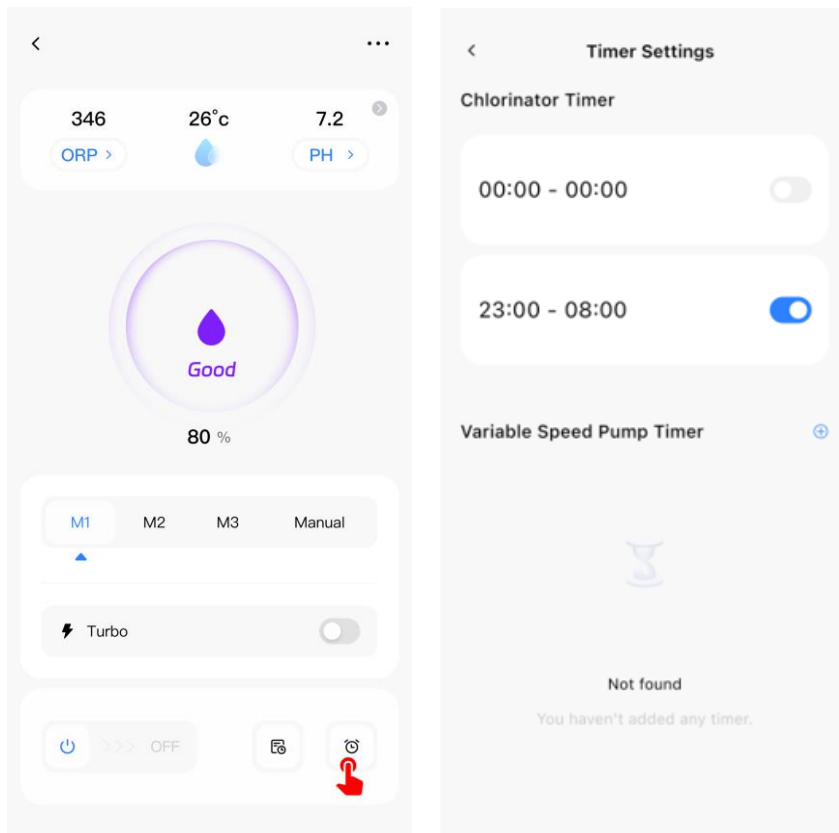

### 10.4 OTA Upgrade

- ① When upgrade is available, upgrade information will pop up and Tap “Update Now”.
- ② Or Tap on the brush icon in the top left corner of the screen to enter the settings screen.
- ③ Tap "Device Upgrade" at the bottom to upgrade.

### 10.5 Device Sharing

- ① Download the “iGarden” app.
- ② Enter the app Settings, tap “Share Device”.
- ③ Add the mobile number of the corresponding person being shared.
- ④ The user being shared can view the device's information simultaneously.

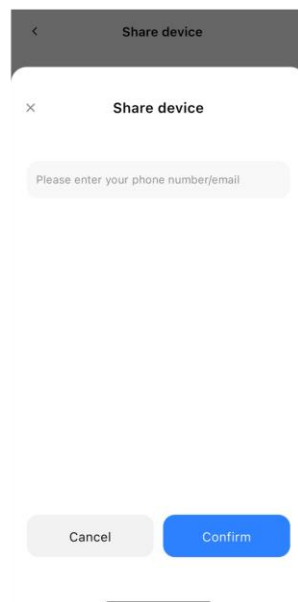
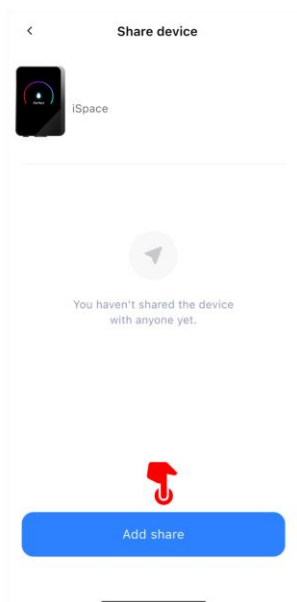
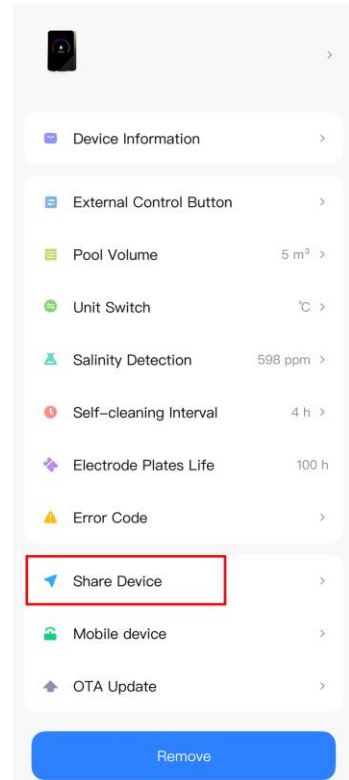
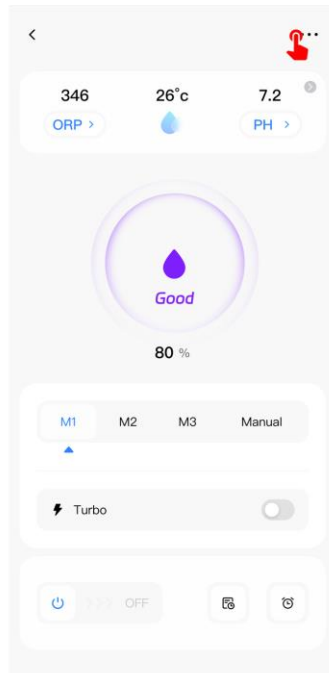
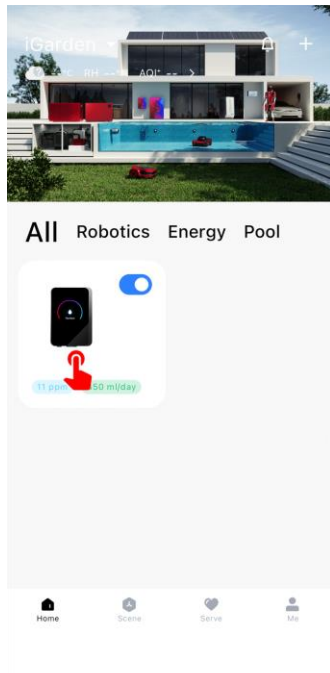

## 10.6 Change Language Settings

- ① Click "Me" in the lower right corner,
- ② Click the "Settings" button in the upper right corner,
- ③ Swipe down and select "Language" to switch to the target language.

# 11 Error Code and Solution

Error Code	Effect	Trigger	Elimination	Remark
<b>A1 ACID TANK</b>	Indicator lights up, normal operation continues.	pH readings failed to reach setpoints.  MPP10, 6 hours MPP16, 12 hours MPP24, 18 hours MPP32, 18 hours MPP36, 18 hours	1. Restart the chlorinator.  2. Automatically resume normal operation, when setting the pH setpoints equals to previous reading.	1. Replenish the acid tank. 2. Check for leakage of the whole dosing system. 3. Try the following steps: - Check pH probe connections - Clean the probe - Calibrate the probe and test pH value again - Replace probe 4. A1 Alarm function can be turned off in <b>【P7】</b>
<b>A2 ADD SALT</b>	Indicator lights up, normal operation continues.	Pool salinity detected is below 750ppm	Automatically resume normal operation, when salinity the higher than minimum threshold.	1. Replenish the salt up to the recommended level(3000-3500ppm). 2. Check the water temperature. 3. Check the cell for excessive scaling or coating loss. 4. A2 Alarm function can be turned off in <b>【P8】</b>
<b>A3 Low TEMP in Cell Warming</b>	Chlorine Production is limited to≤30%	Water temperature detected by temperature sensor is below 10°C	1.Control Unit is < 70°C, chlorinator operates in the preset mode.  2. If E4 was on , Control Unit back to < 68°C, chlorinator operates in the preset mode.	The installation should avoid direct sunlight or high moisture, a sheltered area is more suggested.
<b>A4 Control Unit High Temp Warning</b>	Chlorine Production is limited to≤30%	Internal temperature of control unit is over 70°C	1.Water temp > 10°C, chlorinator operates in the preset mode.  2. If E5 was on , Water temp back to > 12°C, chlorinator operates in the preset mode.	Only shows up when the temperature sensor is installed.

<b>A5 CALIBRATE SENSOR</b>	Indicator lights up, normal operation continues.	No calibration finished for more than 180 days	1. Restore factory default settings 2. Finish calibration.	A5 Alarm function can be turned off in <b>【P9】</b>
<b>E1 Power Supply Abnormal</b>	Pause electrolysis process	When chlorine production is set >5%, but real time DC output detected is too low	Automatically resume normal operation, when the DC output recovers normal range.	1. Check electrodes connection. 2. Check the electrolytic cell for excessive scaling or coating loss. 3. Restart the chlorinator control unit. 4. Please contact the After-Sales Center.
<b>E2 pH setpoint not reached</b>	Pause the acid adding process	pH readings failed to reach setpoints.  MPP10, 24 hours MPP16, 48 hours MPP24, 72 hours MPP32, 72 hours MPP36, 72 hours	1. Restart the chlorinator.  2. Automatically resume normal operation, when setting the pH setpoints equals to previous reading.	1. Test pH with other equipment. 2. Balance the pH level by adding extra chemicals. 3. Try the following in order: ● Check probe connections. ● Clean the probe. ● Calibrate the probe and test PH again. ● Replace probe. 4. E2 Alarm function can be turned off in <b>【P5】</b> .
<b>E3 No flow</b>	Pause electrolysis process and acid adding process	Flow status detected is "OFF"	Automatically resume normal operation, when Flow switch "ON" status is detected.	Insufficient water flow might be caused by: 1. Filtration pump output. 2. Water valve closed. 3. Other possible reasons.
<b>E4 Control Unit Overheat Protection</b>	Pause electrolysis process	Internal temperature of control unit is over 80°C	Automatically resume normal operation, when the Control Unit is below 68°C. E4 and A4 off.	The installation should avoid direct sunlight or high moisture, a sheltered area is more suggested.
<b>E5 Low TEMP in Cell</b>	Cell low temperature protection	Water temperature detected by temperature sensor is below 5°C.	Water temp > 12°C, chlorinator operates in the preset mode, Water temp back to 12°C, E5 and A3 off.	Only shows up when the temperature sensor is installed.
<b>E6 Air in Cell</b>	Pause electrolysis process and acid adding process	The water level is low in electrolysis cell, the air sensor is in contact with air.	Make sure high water level is in the cell, the air sensor is under water level.	Might be caused by: 1. Filtration pump output. 2. Water valve closed. 3. Other possible reasons.

<p><b>E7</b> pH Sensor Failure</p> <p><b>Inverter Auto pH</b></p>	<p>Pause the acid adding process</p>	<p>Hardware communication error occurs inside the control unit.</p>	<p>Hardware communication error occurs inside the control unit.</p>	<ol style="list-style-type: none"> <li>1. Restart the chlorinator control unit.</li> <li>2. Disconnect the power for 10 seconds and re-plug the chlorinator control unit.</li> <li>3. Factory reset</li> <li>4. Please contact the After-Sales Center</li> </ol>
<p><b>E8</b> ORP Sensor Failure</p> <p><b>Inverter</b></p>	<p>Pause electrolysis process</p>	<p>External interference or internal component fault</p>	<p>Power off for 10 s and restart; if unresolved, contact after-sales</p>	<ol style="list-style-type: none"> <li>1. Restart the chlorinator control unit.</li> <li>2. Disconnect the power for 10 seconds and re-plug the chlorinator control unit.</li> <li>3. Factory reset</li> <li>4. Please contact the After-Sales Center</li> </ol>
<p><b>E9</b> Power Module Failure</p>	<p>Pause electrolysis process</p>	<p>External interference or internal component fault</p>	<p>Power off for 10 s and restart; if unresolved, contact after-sales</p>	<ol style="list-style-type: none"> <li>1. Restart the control unit.</li> <li>2. Disconnect the power for 10 seconds and re-plug the control unit.</li> <li>3. Factory reset.</li> <li>4. Please contact the After-Sales Center.</li> </ol>
<p><b>EA</b> ORP Setpoint Not Reached</p> <p><b>Inverter</b></p>	<p>Pause electrolysis process</p>	<p>ORP readings failed to reach setpoints. Alarm on after 72 hours</p>	<p>Automatically resume normal operation, when setting the ORP setpoints equals to previous reading.</p>	<ol style="list-style-type: none"> <li>1. Test the free chlorine level with other equipment, make sure there's enough chlorine in the pool.</li> <li>2. Replenish the pool with proper amount of stabilizer.</li> <li>3. Add Acid to balance pH.</li> <li>4. Activate TURBO mode or add extra chlorine to reduce chloramine.</li> <li>5. Check the cell for scaling or coating loss.</li> <li>6. Try the following in order: <ul style="list-style-type: none"> <li>● Check ORP probe connection.</li> <li>● Clean the probe.</li> <li>● Calibrate the probe and test ORP value.</li> <li>● Replace the probe</li> </ul> </li> <li>7. EA Alarm function can be turned off in <b>【P6】</b></li> </ol>

# 12 After-Sales Support

## Important Information for After-Sales Support

To ensure that we can assist you effectively when you contact our after-sales service, please have the following information ready:

### Product Information

- **Serial Number** (located on the nameplate)
- **Device Virtual ID** (available in the InverGo app)
- Device Model

### Problem Description

- Error Code Display
- Device Readings and Production Status
- Frequency and Timing of Issues

### Usage Environment

- Pool Size, Indoor/Outdoor
- Actual Salinity and ORP, pH, Free Cl Levels
- Water Flow and Filtration Time

Providing this information will help us resolve your issue more efficiently. Thank you!

